

Sample Paper
FINALTERM EXAMINATION
Fall 2022
CS302P – Digital Logic Design (Practical)

Time: 90 min
Marks: 40

MCQ Part

Question No: 1 (Marks: 01) - Please choose the correct option

Generally, for checking the result in a single bit, we use _____ indicator.

- A. Logic Converter
- B. Logic Tester
- C. Probe**
- D. 7-segment Display

Question No: 2 (Marks: 01) - Please choose the correct option

We can simplify a logic circuit using _____ device in Electronic Workbench.

- A. Truth Table
- B. Boolean Algebra
- C. Circuit Minimizer
- D. Logic Converter**

Question No: 3 (Marks: 01) - Please choose the correct option

If $Z = (A+B'+C)'$ then Z will be logic high only if _____.

- A. $A = 1, B = 1, C = 1$
- B. $A = 0, B = 0, C = 0$
- C. $A = 0, B = 1, C = 0$**
- D. $A = 0, B = 0, C = 1$

Question No: 4 (Marks: 01) - Please choose the correct option

A logic circuit having N inputs, can have _____ different input combinations.

- A. $N \times N$
- B. $2 \times N$
- C. $N+2$

D. 2^N

Question No: 5 (Marks: 01) - Please choose the correct option

In a 4-bit odd counter, if the current state is 0001 then the next state will be _____.

- A. 0010
- B. 0000
- C. **0011**
- D. 1100

Question No: 6 (Marks: 01) - Please choose the correct option

The 4-bit grey code for the binary 1001 will be _____.

- A. 1100
- B. 0011
- C. 1111
- D. **1101**

Question No: 7 (Marks: 01) - Please choose the correct option

What will be boolean expression for the function $F(A, B, C) = \Pi(0, 1, 3, 7)$

- A. $(A+B+C)(A+B+C')(A+B'+C')(A'+B'+C')$
- B. $(A+B'+C)(A+B+C')(A'+B'+C)(A+B+C)$
- C. $(A'+B'+C)(A'+B+C')(A'+B+C)(A'+B'+C')$
- D. $(A'+B+C)(A+B'+C)(A+B+C')(A'+B'+C')$

Question No: 8 (Marks: 01) - Please choose the correct option

Which of the following is the correct maxterm ID for the term $x+y'+z$?

- A. M2
- B. M5
- C. m2
- D. m5

Question No: 9 (Marks: 01) - Please choose the correct option

Which of the following gates is used to get the sum output of the full adder circuit?

- A. AND
- B. OR
- C. NOR
- D. **XOR**

Question No: 10 (Marks: 01) - Please choose the correct option

To build an XOR gate using basic gates only, _____ gates can be used?

- A. 4 NAND
- B. 2 NAND
- C. 2 NOR
- D. 4 NOR

Question No: 11 (Marks: 01) - Please choose the correct option

Which of the following is correct expression for carry output in a half-adder circuit?

- A. A XOR B
- B. A NOR B
- C. A AND B
- D. A NAND B

Question No: 12 (Marks: 01) - Please choose the correct option

Consider the given circuit, what value will be displayed on 7-segment display when the simulation is activated?

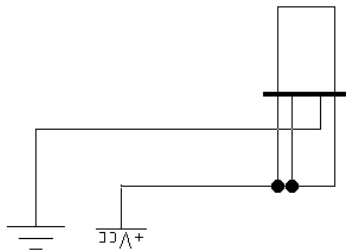

- A. 3
- B. 12
- C. d
- D. 6

Question No: 13 (Marks: 01) - Please choose the correct option

When using full adders to build a 4-bit parallel subtractor circuit, the carry input of which of the full adders is always set to 1?

- A. Full adder corresponding to least significant bit

- B. Full adder corresponding to most significant bit
- C. All 4 full adders are set to 1
- D. None of the full adders are set to 1

Question No: 14 _____ (Marks: 01) - Please choose the correct option _____

Which of the following is not a type of combinational circuit?

- A. Multiplexer
- B. Demultiplexer
- C. Counter**
- D. Full Adder

Question No: 15 _____ (Marks: 01) - Please choose the correct option _____

Which of the following is not a type of sequential circuit?

- A. Counter
- B. Register
- C. Flip-flop
- D. Full Adder**

Question No: 16 _____ (Marks: 01) - Please choose the correct option _____

In a 74151, 1-of-8 Data Sel/Mux, which of the following pins is used as strobe signal?

- A. Y
- B. W
- C. G'**
- D. GND

Question No: 17 _____ (Marks: 01) - Please choose the correct option _____

In a 1-of-8 decoder, what will be the value of output Y when strobe pin is set to logic high?

- A. Y=0**
- B. Y=W
- C. Y=1
- D. Y=D0

Question No: 18 _____ (Marks: 01) - Please choose the correct option _____

In 2-to-4 Line Decoder, which decoder output will be set to 1 for the binary inputs $A = 1$ and $B = 0$?

- A. D0
- B. D1
- C. D2
- D. D3

Question No: 19 (Marks: 01) - Please choose the correct option

What will be boolean expression corresponding to below given decoder circuit?

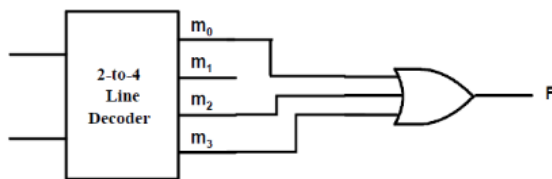

- A. $AB+AB'+A'B$
- B. $AB+A'B'C+A'B$
- C. $AB'+AB+A'B'C$
- D. $AB+A'B'+ABC$

Question No: 20 (Marks: 01) - Please choose the correct option

For which of the following input combination of ground lines of 74138 decoder, all the decoder outputs are set to 1?

- A. $G2A' = X, G2B' = 1, G1 = X$
- B. $G2A' = X, G2B' = X, G1 = X$
- C. $G2A' = 1, G2B' = 1, G1 = X$
- D. $G2A' = X, G2B' = X, G1 = X$

Question No: 21 (Marks: 01) - Please choose the correct option

For which of the following combinations of ground input lines, all the output lines of 74138 decoder correspond to stored address 0?

- A. $G2A' = X, G2B' = 1, G1 = X$
- B. $G2A' = X, G2B' = X, G1 = X$
- C. $G2A' = 1, G2B' = 0, G1 = 1$
- D. $G2A' = X, G2B' = X, G1 = X$

Question No: 22 (Marks: 01) - Please choose the correct option

To create a binary to gray code converter circuit by using the logic gates only, which of the following gates is used?

- A. AND
- B. OR
- C. NAND
- D. XOR

Question No: 23 (Marks: 01) - Please choose the correct option

Consider the below given K-Map. The simplified expression corresponding to this K-map will be _____?

	YZ	00	01	11	10
WX			1		
			1		
		1	1		

- A. $W Y' Z + W 'Y' Z$
- B. $W X Y' + W' Y' Z$
- C. $W Y' Z' + W Y' Z$
- D. $W Y Z' + W Y Z$

Question No: 24 (Marks: 01) - Please choose the correct option

Which of the examples below expresses the commutative law of multiplication?

- A. $A + B = B + A$
- B. $A \cdot B = B + A$
- C. $A \cdot (B \cdot C) = (A \cdot B) \cdot C$
- D. $A \cdot B = B \cdot A$

Descriptive Part

Question No: 25 (Marks: 05)

Consider the below given truth table corresponding to 3-input boolean function. Implement the given function in Electronics Workbench by using 74138 decoder.

Inputs			Output
A	B	C	F
0	0	0	1
0	0	1	0
0	1	0	0
0	1	1	1
1	0	0	1
1	0	1	0
1	1	0	1
1	1	1	0

Solution:

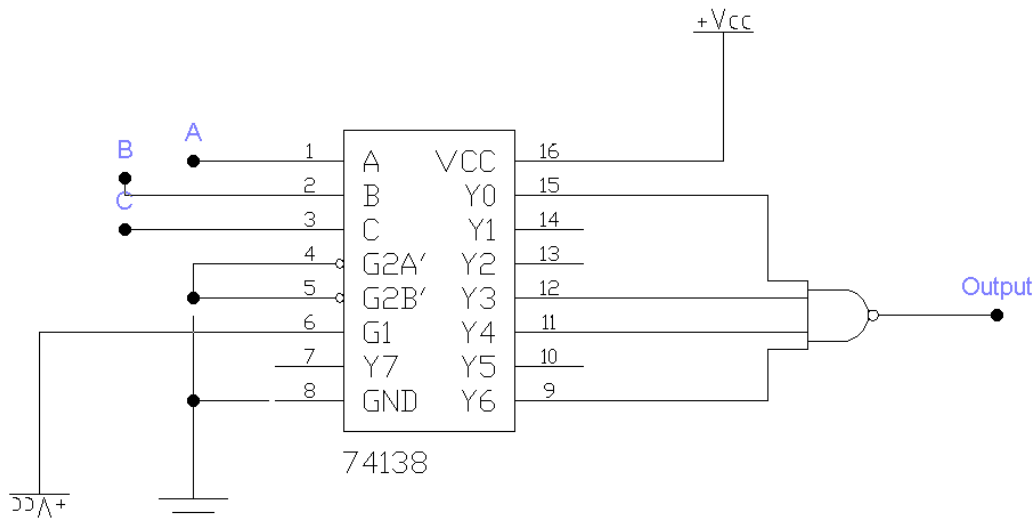

Question No: 26 (Marks: 05)

Realize the below given 4-variable function by using 16x1 multiplexer in Electronics Workbench.

$$F(A, B, C, D) = A'B'C'D' + A'BC'D + ABC'D' + A'BC'D' + AB'C'D'$$

Solution:

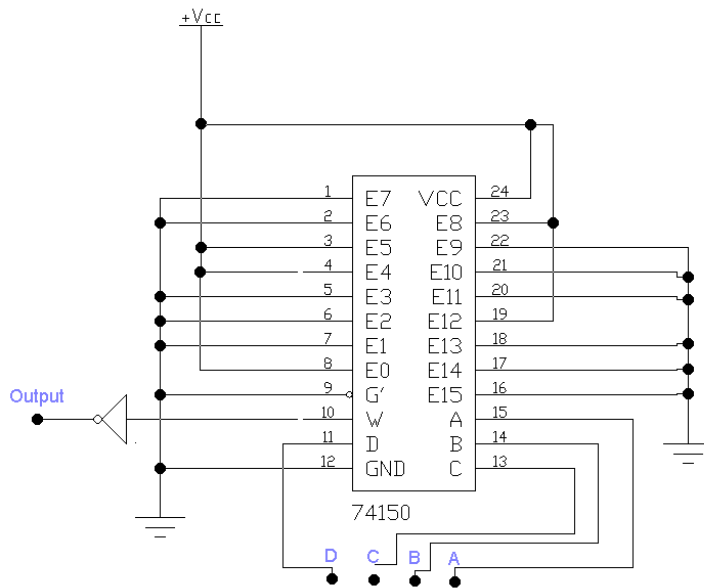

Question No: 27 (Marks: 05)

Simplify the given boolean function by using boolean algebra rules.

$$F = AB + (AC)' + AB'C(AB + C)$$

Solution:

$$\begin{aligned}
 F &= AB + (AC)' + AB'C(AB + C) \\
 &= AB + A' + C' + AB'C.AB + AB'C.C \\
 &= AB + A' + C' + 0 + AB'C && (B.B' = 0 \text{ and } C.C = C) \\
 &= ABC + ABC' + A' + C' + AB'C && (AB = AB(C + C')) \\
 &= ABC + ABC' + A' + C' + AB'C \\
 &= AC(B + B') + C'(AB + 1) + A' \\
 &= AC + C' + A' && (B + B' = 1 \text{ and } AB + 1 = 1) \\
 &= AC + (AC)' = 1
 \end{aligned}$$

Question No: 28 (Marks: 05)

Simplify the following Boolean expression using Karnaugh map:

$$F(w,x,y,z) = \Sigma(1,3,7,11,15) + x(0,2,5,8)$$

Solution:

The K-Map corresponding to given expression is as follows:

WX/YZ	00	01	11	10
-------	----	----	----	----

00	x	1	1	x
01		x	1	
11			1	
10	x		1	

There will be two minterm groups in the given K-Map as following:

WX/YZ	00	01	11	10
00	x	1	1	x
01		x	1	
11			1	
10	x		1	

The simplified expression will be $f(w,x,y,z) = w'x' + yz$

Question No: 29 (Marks: 05)

Implement a 3-bit parallel subtractor circuit in the Electronics Workbench which subtracts the decimal 2 from decimal 5 and displays the result on a 7-segment display.

Solution:

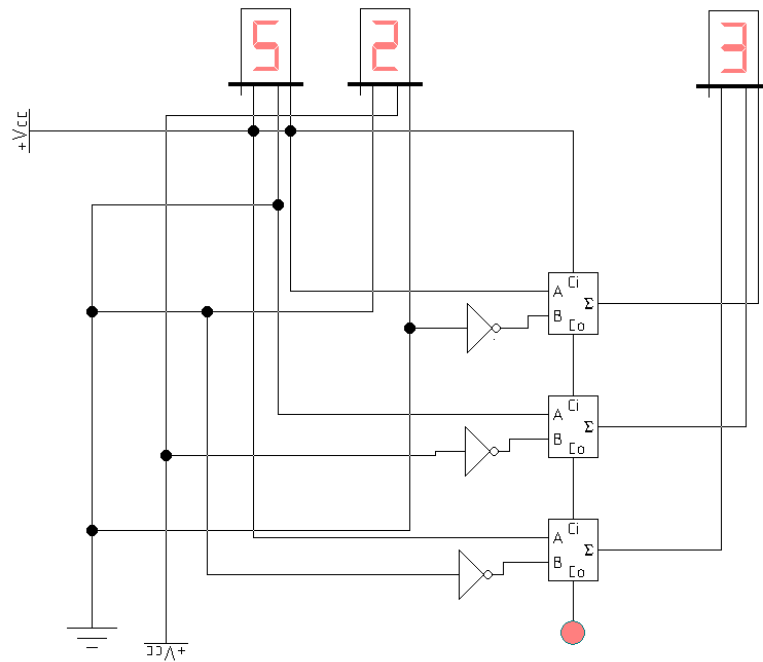

Question No: 30 (Marks: 05)

Build a 2-bit up counter in Electronics Workbench by using a D-Flop Flip.

Solution:

