

COMPUTER NETWORKS (CS610)

HANDOUTS

LECTURERS # 01 – 45

PREPARED BY:

HAMMAD KHALID KHAN

Lecture No. 23

INTERNETWORKING: CONCEPTS, ARCHITECTURE AND PROTOCOLS

THE MOTIVATION FOR INTERNETWORKING:

There is no single networking technology that is best for all needs. A large organization with diverse networking requirements needs multiple physical networks. If the organization chooses the type of network that is best for each task, the organization will need several types of networks.

The interconnection of two or more networks, usually local area networks so that data can pass between hosts on the different networks as though they were one network, this requires some kind of Router or Gateway, which led to the motivation for internetworking.

THE CONCEPT OF UNIVERSAL SERVICE:

The chief problems with multiple networks are as follows:

- A computer attached to a given network can only communicate with other computers attached to the same network.
- In the 1970s large organizations began to acquire multiple networks. Each network in the organization formed island. Employees needed to choose a computer appropriate for each task. So they needed multiple screens, keyboards and computers.

UNIVERSAL SERVICES:

A communication system that supplies universal services allows arbitrary pairs of computers to communicate.

Universal service is desirable because it increases individual productivity.

UNIVERSAL SERVICES IN A HETEROGENEOUS WORLD:

Although universal service is highly desirable incompatibilities among network hardware and physical addressing prevent an organization from building a bridged network that includes arbitrary technologies.

Extension techniques such as bridging cannot be used with heterogeneous network because of incompatible packet formats.

INTERNETWORKING:

Despite the incompatibilities among networks, researchers have devised a scheme that provides universal service among heterogeneous networks called 'internetworking'. It uses both hardware and software.

PHYSICAL NETWORK CONNECTION WITH ROUTERS:

A router is a special purpose system dedicated to the task of interconnecting networks. A router can interconnect networks that use different technologies including different media, physical addressing schemes or frame formats. A router connecting two physical networks is shown in the figure below.



Figure 23.1

INTERNET ARCHITECTURE:

Organization seldom uses a single router to connect its entire network for two reasons.

- Because the router must forward each packet, the processor in a given router is insufficient to handle the traffic.
- Redundancy improved Internet reliability.

An Internet consists of a set of networks interconnected by routers. The Internet scheme allows each organization to choose the number and type of network, the number of routers to use to interconnect them, and the exact interconnection topology. Three routers connecting four networks in series is shown in the figure below.



Figure 23.2

ACHIEVING UNIVERSAL SERVICES:

The goal of internetworking is universal service across heterogeneous networks. To provide this service all computers and routers must agree to forward information from a source on one network to a specified destination. The task is complicated as frame formats and addressing schemes may differ. The key of achieving universal service is universal protocol software (TCP/IP).

A virtual network is shown in the figure that TCP/IP software provides to users and applications.

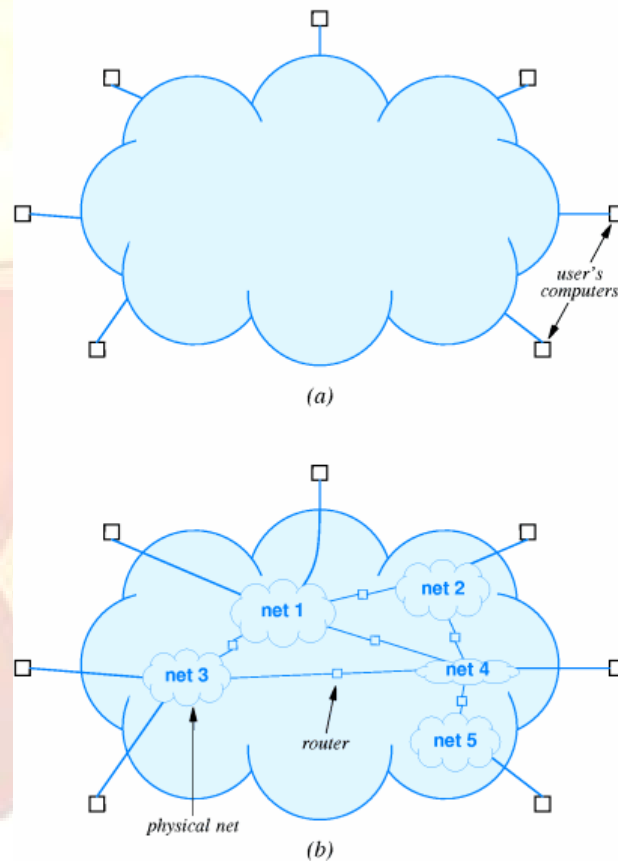

Figure 23.3

LAYERING AND TCP/IP PROTOCOLS:

TCP/IP protocols are organized into five conceptual layers. Although some layers of the TCP/IP reference model correspond to layers of the ISO reference model, the ISO layers scheme does not have a layer that corresponds to TCP/IP Internet Layer.

TCP/IP reference model is shown in the figure below.

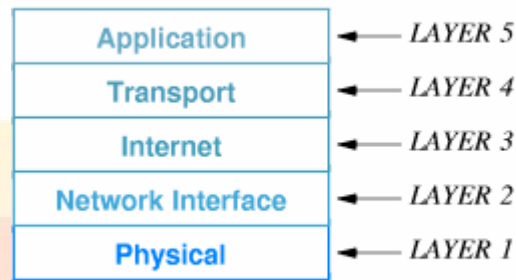

Figure 23.4

LAYER 1:

Corresponds to basic network hardware layer in OSI.

LAYER 2:

Specifies how to organize data in frames.

LAYER 3:

Specifies the format of packets sent across an Internet and forwards packets.

LAYER 4:

Specifies how to ensure reliable transfer.

LAYER 5:

Like 6 and 7 in OSI model, it specifies how one application uses an Internet.

HOST COMPUTERS, ROUTERS AND PROTOCOL LAYERS:

TCP/IP defines the term host computer to refer to any computer system that connects to an Internet and runs applications. A TCP/IP protocol makes it possible for any pair of hosts to communicate despite hardware differences.

Both host and routers need TCP/IP protocol software but routers do not need layer 5 protocols for applications, as they do not run applications.

Lecture No. 24

IP: INTERNET PROTOCOL ADDRESSES

ADDRESSES FOR THE VIRTUAL INTERNET:

To provide uniform addressing in Internet, protocol software defines an abstract addressing scheme that assigns each host a unique protocol address.

Users, application programs and higher layers of protocol software use the abstract protocol software addresses to communicate.

THE IP ADDRESSING SCHEME:

An Internet address (IP address) is a unique 32-bit binary number assigned to a host and used for all communication with the host. Each packet sent across an Internet contains the 32-bit IP address of the sender (source) as well as the intended recipient (destination).

THE IP ADDRESS HIERARCHY:

Each 32-bit IP address is divided into two parts:

PREFIX:

It identifies the physical network to which the computers are attached.

SUFFIX:

It identifies an individual computer on the network.

The physical network in an Internet is assigned a unique value known as a network number. No two networks can be assigned the same network number and no two computers on the same network can be assigned the same suffix. A suffix value can be used on more than one network.

The IP address hierarchy guarantees two important principles:

1. Each computer is assigned a unique address.
2. Although network number assignment must be coordinated globally, suffixes can be assigned locally.

ORIGINAL CLASSES OF IP ADDRESSES:

The original IP address scheme divides host addresses into three primary classes. The class of an address determines the boundary between the network prefix and suffix. The original classes of IP addresses are shown in the figure below.

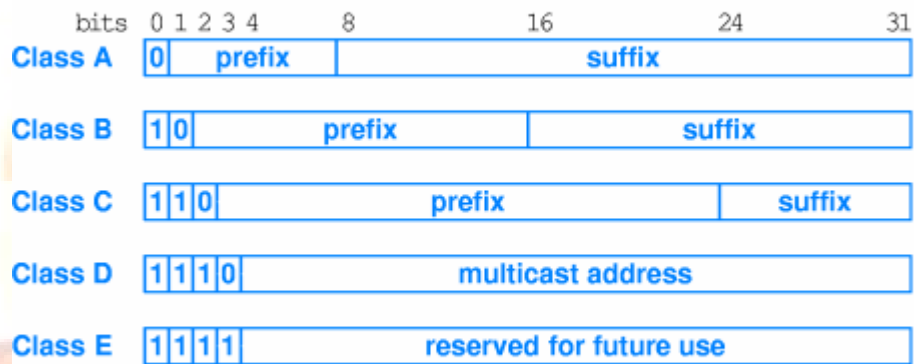

Figure: 24.1

Lecture No. 25

INTERNET PROTOCOL ADDRESS NOTATIONS

COMPUTING THE CLASS OF AN ADDRESS:

Whenever it handles a packet, IP software needs to separate the destination address into a prefix and suffix. Classful IP addresses are self-identifying because the class of the address can be computed from the address itself. The table shows in the figure below how the class of address can be computed.

First Four Bits Of Address	Table Index (in decimal)	Class of Address
0000	0	A
0001	1	A
0010	2	A
0011	3	A
0100	4	A
0101	5	A
0110	6	A
0111	7	A
1000	8	B
1001	9	B
1010	10	B
1011	11	B
1100	12	C
1101	13	C
1110	14	D
1111	15	E

Figure: 25.1

DOTTED DECIMAL NOTATION:

Dotted decimal notation is a syntactic form the IP software uses to express 32-bit binary values when interacting with humans. Dotted decimal represents each octet in decimal and uses a dot to separate octets. This is shown in the figure below.

32-bit Binary Number	Equivalent Dotted Decimal
10000001 00110100 00000110 00000000	129 . 52 . 6 . 0
11000000 00000101 00110000 00000011	192 . 5 . 48 . 3
00001010 00000010 00000000 00100101	10 . 2 . 0 . 37
10000000 00001010 00000010 00000011	128 . 10 . 2 . 3
10000000 10000000 11111111 00000000	128 . 128 . 255 . 0

Figure 25.2

CLASSES AND DOTTED DECIMAL NOTATION:

The relationship between classes and dotted decimal notation is given as follows.
 In class A the three octets correspond to a host suffix.
 In class B the last two octets are the host octets.
 Class C has only one octet to represent the host.
 The range of decimal values found in the first octet of each address class is given below in the figure.

Class	Range of Values
A	0 through 127
B	128 through 191
C	192 through 223
D	224 through 239
E	240 through 255

Figure: 25.3

DIVISION OF THE ADDRESS SPACE:

The IP class scheme does not divide the 32-bit address space into equal size class and the classes do not contain the same number of networks.

A prefix of n bits allows 2^n unique network number, while a suffix of n bits allows 2^n host numbers to be assigned on a given network. This is shown in the table below.

Address Class	Bits In Prefix	Maximum Number of Networks	Bits In Suffix	Maximum Number Of Hosts Per Network
A	7	128	24	16777216
B	14	16384	16	65536
C	21	2097152	8	256

Figure 25.4

AUTHORITY FOR ADDRESSES:

Throughout the Internet, each network prefix is unique. Networks obtain their network numbers from their Internet service provider (ISP). The Internet service providers coordinate with the Internet assigned number authority to obtain their network numbers.

CLASSFUL ADDRESSING EXAMPLE:

Here we have a private TCP/IP network, which consists of four physical networks as shown in the figure below.

The first step is to assign IP addresses in which usually class C addresses are assigned. Network administrator computes the ultimate size of each physical network and assigns a prefix.

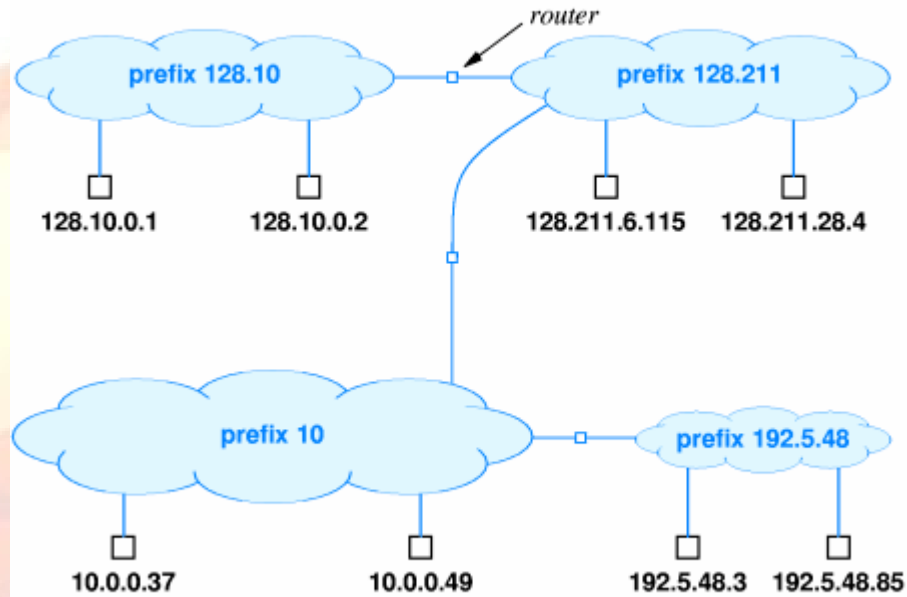

Figure: 25.5

Lecture No. 26

IP SUBNETTING

SUBNETS AND CLASSLESS ADDRESSING:

As the Internet grew, the original Classful addressing scheme became a limitation. The IP address space was being exhausted because all networks had to choose one of three possible sizes. Many addresses were unused.

Two new mechanisms were invented to overcome the limitations, which are as follows:

- Subnet addressing
- Classless addressing

Instead of having three distinct address classes, allow the division between prefix and suffix to occur on an arbitrary boundary. The classless addressing scheme solves the problem by allowing an ISP to assign a prefix that is, 28 bits long (allowing the host to have up to 14 hosts).

SUBNET/ADDRESS MASK:

How can an IP address be divided at an arbitrary boundary? To use a classless or subnet address, table inside hosts and routers that contain address must keep two pieces of information with each address: the 32-bit address itself and another 32-bit value that specifies the boundary that is known as the Address Mask or Subnet Mask.

Suppose

D = Destination Address

(A, M) = (32-bit IP Address, 32-bit Address Mask)

$A = (D \& M)$

Now as an example consider a 32-bit mask:

11111111 11111111 00000000 00000000

Which can be denoted in dotted decimal as 255.255.0.0.

Consider a network prefix:

10000000 00001010 00000000 00000000

Which can be denoted in dotted decimal value as 128.10.0.0.

Consider a destination address: 128.10.2.3

That has Binary equivalent as:

10000000 00001010 00000010 00000011

A logical 'and' between D and M produces the binary result as:

10000000 00001010 00000000 00000000

Which is equal to prefix 128.10.0.0.

CIDR NOTATION:

Inside a computer, each address mask is stored as a 32-bit value. When we enter a prefix and an address mask they use a modified form of dotted decimal addressing called CIDR addressing, which is known as CIDR Notation.

As an example how CIDR adds flexibility, suppose a single class B prefix (e.g. 128.211.0.0) i.e. 216 host addresses 16-bit CIDR mask denoted as:
128.211.0.0/16

That is, by making CIDR mask corresponds exactly to the old Classful interpretation. It will be fine if 216 hosts are attached. If it does have two customers with only twelve computers each, the ISP can use CIDR to partition the address into three pieces.

- Two of them each big enough for one of two customers.
- Remainder available for future customers.

For example one customer can be assigned 128.211.0.16/28 and the other customer can be assigned 128.211.0.32/28. Both customers have same mask size, the prefix differs i.e. each customer has a unique prefix.

CIDR HOST ADDRESSES:

The example below in the figure shows the CIDR host addresses:

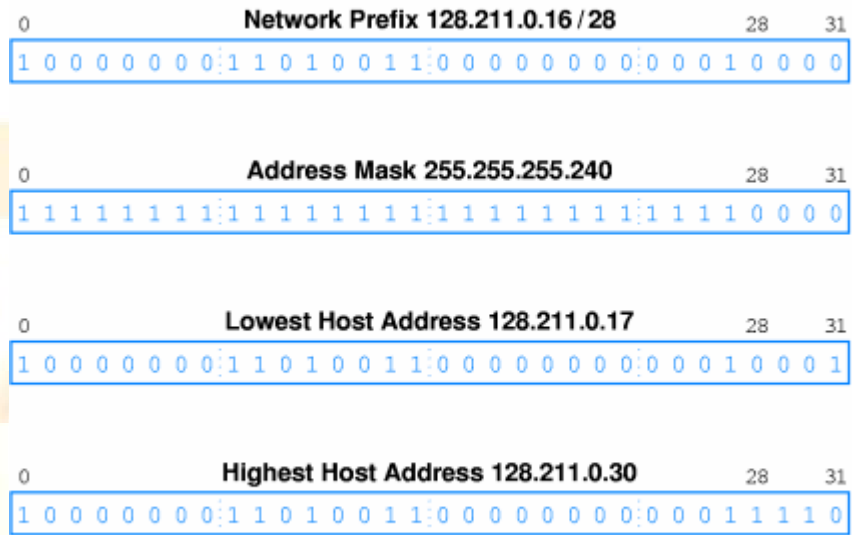

Figure: 26.1

SUMMARY OF SPECIAL IP ADDRESSES:

The table below shows a summary of special IP addresses.

Prefix	Suffix	Type Of Address	Purpose
all-0s	all-0s	this computer	used during bootstrap
network	all-0s	network	identifies a network
network	all-1s	directed broadcast	broadcast on specified net
all-1s	all-1s	limited broadcast	broadcast on local net
127	any	loopback	testing

Figure 26.2

Lecture No. 27

ADDRESS RESOLUTION PROTOCOL (ARP)

PROTOCOL ADDRESSES AND PACKET DELIVERY:

Protocol addresses are abstractions provided by software. Physical network hardware does not know how to locate a computer from its protocol address. The protocol address of the next hop must be translated to an equivalent hardware address before a packet can be sent.

ADDRESS RESOLUTION:

Mapping between a protocol address and a hardware address is called Address Resolution. A host or router uses address resolution when it needs to send a packet to another computer on the same physical network. A computer never resolves the address of a computer that attaches to a remote network.

In the figure below a simple Internet with routers R1 & R2 connecting three physical networks is shown. Each network has two host computers attached.

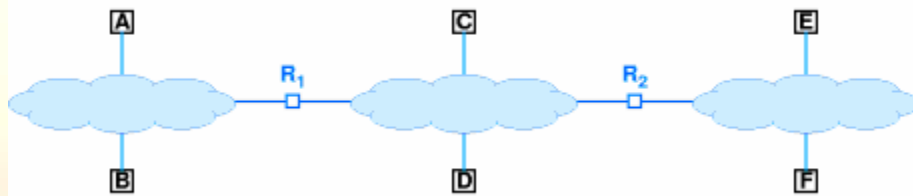

Figure 27.1

In the figure, A resolves protocol address for B for protocol messages from an application on A sent to an application on B. A does not resolve a protocol address for F. Through the Internet layer, A delivers to F by routing through R1 and R2. A resolves R1 hardware address.

Network layer on A passes packet containing destination protocol address F for delivery to R1.

ADDRESS RESOLUTION TECHNIQUES:

Address resolution algorithms can be grouped into three basic categories:

- Table lookup
- Closed-form computation

- Message Exchange

1. TABLE LOOKUP:

In Table Lookup, binding or mapping is stored in a table in memory, which the software searches when it needs to resolve an address.

2. CLOSED-FORM COMPUTATION:

In Closed-form computation, the protocol address assigned to a computer is chosen carefully so that computer's hardware address can be computed from the protocol address using basic Boolean and arithmetic operations.

3. MESSAGE EXCHANGE:

In Message Exchange, Computers exchange messages across a network to resolve an address. One computer sends a message that requests an address binding (translation) and another computer sends a reply that contains the requested information.

Now we discuss in some detail these three categories.

ADDRESS RESOLUTION WITH TABLE LOOKUP:

Resolution requires data structure that contains information about address binding. A separate address-binding table is used for each physical network. The chief advantage of the table lookup approach is generality; a table can store the address bindings for an arbitrary set of computers.

For less than a dozen hosts, a sequential search can suffice. For large networks the sequential approach uses too much CPU time. In the table below the hardware addresses for their corresponding IP addresses are given.

IP Address	Hardware Address
197.15.3.2	0A:07:4B:12:82:36
197.15.3.3	0A:9C:28:71:32:8D
197.15.3.4	0A:11:C3:68:01:99
197.15.3.5	0A:74:59:32:CC:1F
197.15.3.6	0A:04:BC:00:03:28
197.15.3.7	0A:77:81:0E:52:FA

Figure 27.2

There are two standard implementations to improve computational efficiency:

- Hashing
- Direct indexing

HASHING:

Hashing is the transformation of a string of characters into a usually shorter fixed-length value or a key that represents the original string. Hashing is used to index and retrieve items in a database because it is faster to find the item using the shorter hashed key than to find it using the original value. It is also used in many encryption algorithms.

DIRECT INDEXING:

It is less generally known technique. It is possible only in cases where protocols address are assigned from a compact range. In the figure below an example of direct lookup for a class C network is shown.

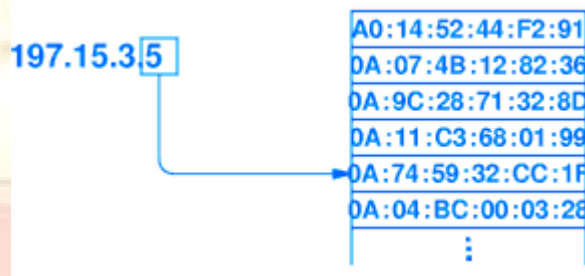

Figure 27.3

ADDRESS RESOLUTION WITH CLOSED-FORM COMPUTATION:

For networks use configurable addressing, it is possible to choose an address that makes closed-form address resolution possible. A re-solver is used to compute a mathematical function that maps an IP address to a hardware address.

When a computer connects to a network that uses configurable address, the local network administrator must choose a hardware address as well as an IP address. The two values can be chosen to make address resolution trivial. Let's consider an example.

EXAMPLE:

Suppose a configurable network number:

220.123.5.0/24

The IP address of first host = 220.123.5.1

Hardware Address = 1

The IP address of second host = 220.123.5.2

Hardware Address = 2

The IP address of router = 220.123.5.101

Hardware Address = 101

A simple Boolean 'and' operation can compute the computer's hardware address.

Hardware Address = ip_address & 0xff

ADDRESS RESOLUTION WITH MESSAGE EXCHANGE:

An alternative to local computations is a distributed approach. A computer that needs to resolve an address sends a message across a network and receives a reply. The message carries a request that species the protocol address and reply carries the corresponding hardware address.

In this category there are two possible designs:

- Centralized
- Distributed

CENTRALIZED:

A network includes one or more servers that are assigned the task of answering address resolution requests. It has an advantage that resolution is easier to configure, manage and control.

DISTRIBUTED:

Each computer on the network participates in address resolution by agreeing to answer resolution request for its address. It also has an advantage that address resolution servers can become a bottleneck and reduce cost.

Lecture No. 28

ARP MESSAGE FORMAT

ADDRESS RESOLUTION SUMMARY:

It is shown in the figure below, in which T stands for Table lookup, C for Closed-form Computation and D for Data Exchange.

Feature	Type Of Resolution
Useful with any hardware	T
Address change affects all hosts	T
Protocol address independent of hardware address	T, D
Hardware address must be smaller than protocol address	C
Protocol address determined by hardware address	C
Requires hardware broadcast	D
Adds traffic to a network	D
Produces resolution with minimum delay	T, C
Implementation is more difficult	D

Figure 28.1

ADDRESS RESOLUTION PROTOCOL:

TCP/IP can use any of the three address resolution methods depending on the addressing scheme used by the underlying hardware. To guarantee that all computers agree on the exact format and meaning of message used to resolve addresses. The TCP/IP protocol suite includes an Address Resolution Protocol (ARP).

The ARP standard defines two basic message types:

- Request
- Response

REQUEST:

This contains an IP address and requests the corresponding hardware address.

RESPONSE:

This contains both the IP address sent in the request and the hardware address.

ARP MESSAGE DELIVERY:

ARP message delivery is shown in the figure below.

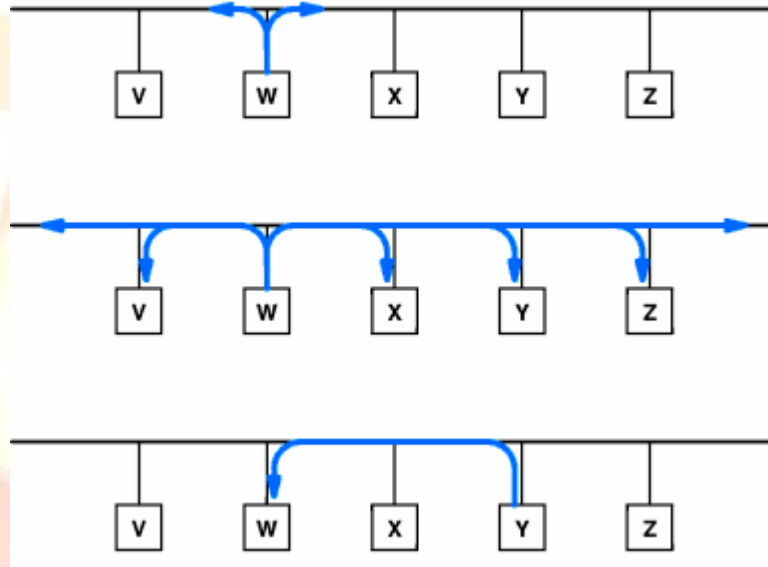

Figure 28.2

ARP MESSAGE FORMAT:

Although the ARP message format is sufficiently general to allow arbitrary protocol and hardware addresses. ARP is almost always used to bind a 32-bit IP address to a 48-bit Ethernet address.

ARP format is shown in the figure below:

0	8	16	24	31
HARDWARE ADDRESS TYPE		PROTOCOL ADDRESS TYPE		
HADDR LEN	PADDR LEN	OPERATION		
SENDER HADDR (first 4 octets)				
SENDER HADDR (last 2 octets)		SENDER PADDR (first 2 octets)		
SENDER PADDR (last 2 octets)		TARGET HADDR (first 2 octets)		
TARGET HADDR (last 4 octets)				
TARGET PADDR (all 4 octets)				

Figure 28.3

SENDING AN ARP MESSAGE:

When one computer sends an ARP message to another the message travels inside the hardware frame. Technically, placing a message inside a frame for transport is called encapsulation as shown in the figure below.

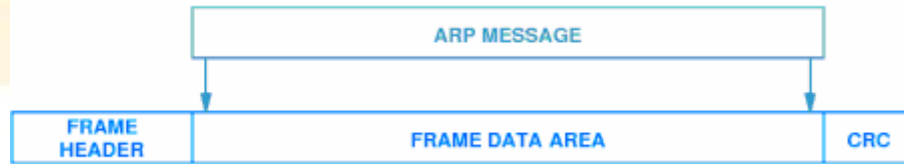

Figure 28.4

IDENTIFYING ARP RESPONSES:

Let's find out how a computer knows whether an incoming frame contains an ARP message. The type field in the frame header specifies that the frame contain an ARP message. The Ethernet standard specifies that the type field in an Ethernet frame carrying an ARP message must contain the hexadecimal value 0 x 806, as shown in the figure below.

Dest. Address	Source Address	Frame Type	Data In Frame
		806	complete ARP message

Figure 28.5

CASHING ARP RESPONSES:

Although message exchange can be used to bind addresses, sending a request for each binding is hopelessly inefficient. To reduce network traffic, ARP software extracts and saves the information from a response so that it can be used for subsequent packets. ARP manages the Table as a cache short-term storage.

PROCESSING AN INCOMING ARP MESSAGE:

When an ARP message arrives, the protocol specifies that the receiver must perform two basic steps.

First the receiver extracts the sender's addresses binding and checks to see if it is present in the cache. If not, it updates the cache.

The receiver examines the operation field of the message to determine whether the message is a request or a response. If the message is a request, the receiver compares

the field TARGET PADDR with the local protocol address. If the two are identical, the computer is the target of the request and must send an ARP response.

LAYERING, ADDRESS RESOLUTION AND PROTOCOL ADDRESSES:

ADDRESSES:

Address resolution (ARP) is a network interface layer function. Protocol addresses are used in all higher layers. Address resolution software hides ugly details and allows generality in upper layers. This is shown in the figure below.

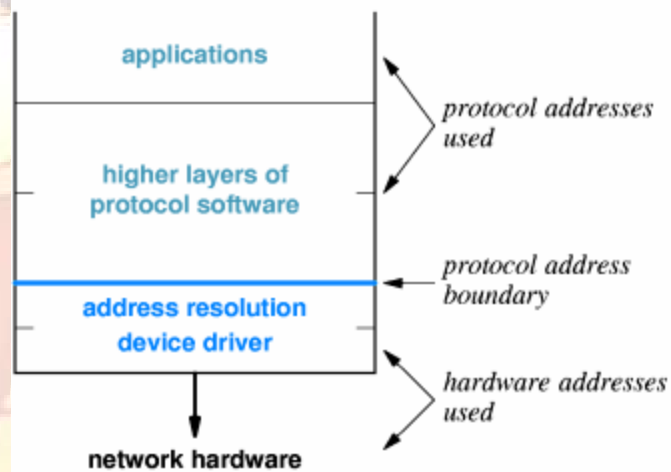

Figure 28.6

Lecture No. 29

IP DATAGRAMS AND DATAGRAM FORWARDING

CONNECTIONLESS SERVICE:

End-to-end delivery service is connection less. The main features of connectionless service are as follows:

It includes extension of LAN abstraction. It has universal addressing and the data is delivered in packets (frames), each with a header. It combines collection of physical networks into a single virtual network.

Transport protocols use this connectionless service to provide:

- Connectionless data delivery (UDP)
- Connection-oriented data delivery (TCP)

VIRTUAL PACKETS:

These packets serve same purpose in Internet as frames on LAN. Each packet has a header. Routers, which are formally gateways, forward packets between physical networks.

These packets have a uniform hardware-independent format. They include header and data and can't use format from any particular hardware. They are encapsulated in hardware frames from delivery across each physical network.

IP DATAGRAM FORMAT:

Formally, the unit of IP data delivery is called a Datagram. It includes header area and data area as shown in the figure below.



Figure 29.1

IP DATAGRAM SIZE:

Datagrams can have different sizes i.e.

Header area is usually fixed (20 octets) but can have options. Data area can contain between 1 octet and 65,535 octets (2¹⁶-1). Usually, data area is much larger than header.

FORWARDING DATAGRAMS:

Header contains all information needed to deliver datagram to the destination computer. It contains:

- Destination address
- Source address
- Identifier
- Other delivery information

Router examines header of each datagram and forwards datagram along path to destination.

ROUTING TABLE:

For efficiency, information about forwarding is stored in a routing table, which is initialized at system initialization and must be updated as network topology changes. The routing table contains list of destination networks and next hop for each destination. An example routing table is shown in the figure below.



Destination	Next Hop
net 1	R ₁
net 2	deliver direct
net 3	deliver direct
net 4	R ₃

(b)

Figure 29.2

ROUTING TABLES AND ADDRESS MASKS:

In practice, additional information is kept in routing table. Destination is stored as network address. Next hop is stored as IP address of router. Address mask defines how many bits of address are in prefix. Prefix defines how much of address used to identify network.

For example, class A mask is 255.0.0.0 which is used for subnetting. A routing table with address masks is shown in the figure below:

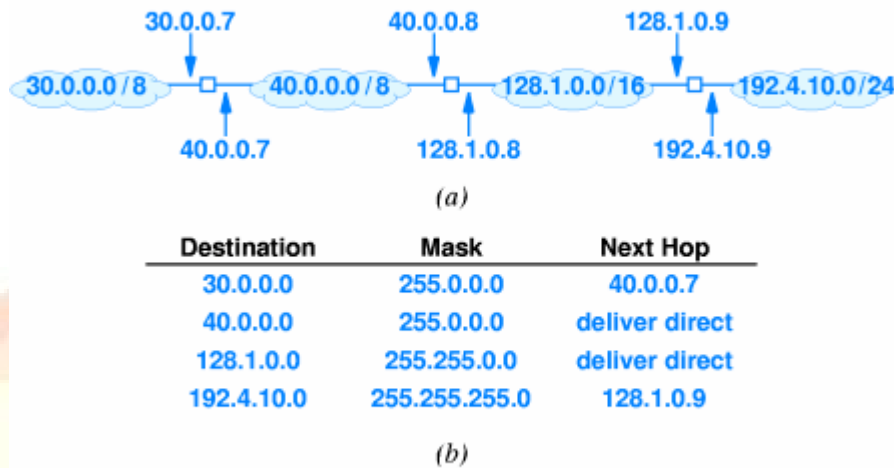

Figure 29.3

ADDRESS MASKS:

To identify destination, network apply address mask to destination address and compare to network address in routing table. It can use Boolean 'and' to compute the ith entry in the table.

i.e.

if $((\text{Mask}[i] \& D) == \text{Dest}[i])$ forward to $\text{NextHop}[i]$

FORWARDING, DESTINATION ADDRESS AND NEXT-HOP:

Destination address in IP datagram is always ultimate destination. Router looks up next-hop address and forwards datagram. Network interface layer takes two parameters:

- IP datagram
- Next-hop address

Next-hop address never appears in IP datagram.

BEST-EFFORT DELIVERY:

IP provides service equivalent to LAN. It does not guarantee to prevent duplicate datagrams, delayed or out-of-order delivery, corruption of data and datagram loss.

Transport layer provides reliable delivery. Network layer – IP – can detect and report errors without actually fixing them. It focuses on datagram delivery. Application layer is not interested in differentiating among delivery problems at intermediate routers.



Lecture No. 30

IP ENCAPSULATION, FRAGMENTATION AND REASSEMBLY

It is shown in the figure below:

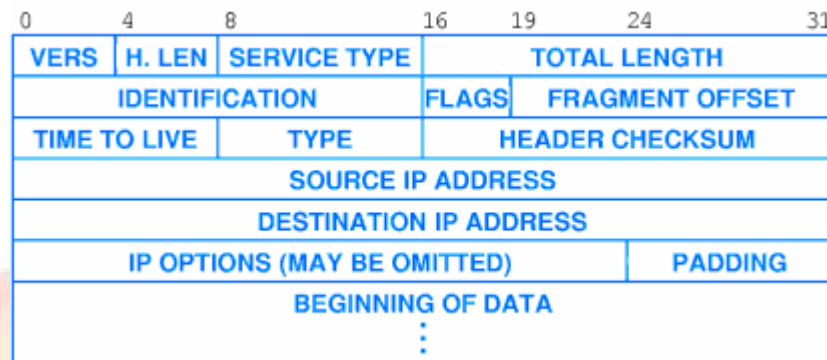

Figure 30.1

In the figure:

VERS shows the version of IP.

H.LEN shows the header length in units of 32-bits.

SERVICE TYPE shows sender's preference for low latency, high reliability that is rarely used.

TOTAL LENGTH shows total octets in datagram.

IDENT, FLAGS, FRAGMENT OFFSET show the values used with fragmentation.

TTL shows time to live decremented in each router; datagram discarded when TTL = 0.

TYPE shows type of protocol carried in datagram e.g., TCP, UDP.

HEADER CHECKSUM shows 1's complement of 1's complement sum.

SOURCE DIST IP ADDRESS shows IP addresses of original source and ultimate destination.

IP DATAGRAM OPTIONS:

Several options can be added to IP header, e.g., record route, source route and timestamp. Header with no options has H. LEN field value 5; data begins immediately after DESTINATION IP ADDRESS. Options are added between DESTINATION IP ADDRESS and data in multiples of 32 bits. Header with 96 bits of options has H. LEN field value 8.

DATAGRAM TRANSMISSION AND FRAMES:

IP Internet layer has following tasks:

- It constructs datagram, determines next hop and hands to network interface layer.

Network interface layer has following tasks:

- It binds next hop address to hardware address and prepares datagram for transmission. But hardware frame doesn't understand IP how datagram is transmitted?

ENCAPSULATION:

Network interface layer encapsulates IP datagram as data area in hardware frame. Hardware ignores IP datagram format. Standards for encapsulation describe details. Standard defines data type for IP datagram, as well as others (e.g., ARP). Receiving protocol stack interprets data area based on frame type. The encapsulation process is shown in the figure below.



Figure 30.2

ENCAPSULATION ACROSS MULTIPLE HOPS:

Each router in the path from the source to the destination un-encapsulates incoming datagram from frame, processes datagram and determines next hop and encapsulates datagram in outgoing frame. Datagram may be encapsulated in different hardware format at each hop. Datagram itself is (almost) unchanged as shown in the figure below.

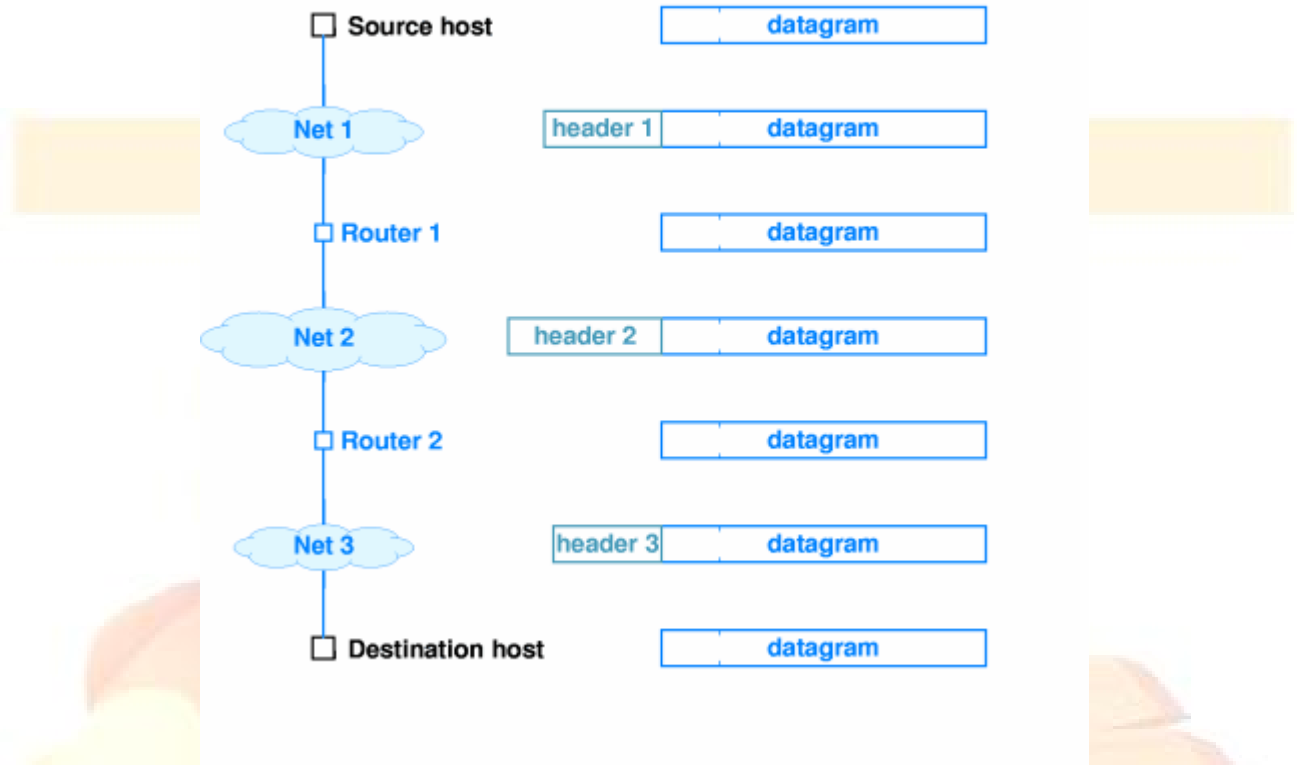

Figure 30.3

MTU:

Every hardware technology specification includes the definition of the maximum size of the frame data area, which is called the Maximum Transmission Unit (MTU). Any datagram encapsulated in a hardware frame must be smaller than the MTU for that hardware.

MTU AND HETEROGENEOUS NETWORKS:

An Internet may have networks with different MTUs as shown in the figure below. Suppose downstream network has smaller MTU than local network.



Figure 30.4

FRAGMENTATION:

One technique is to limit datagram size to smallest MTU of any network. IP uses fragmentation i.e. datagrams can be split into pieces to fit in network with small MTU.

Router detects datagram larger than network MTU and then it splits into pieces and each piece is smaller than outbound network MTU.

Each fragment is an independent datagram. It includes all header fields. Bit in header indicates that the datagram is a fragment. Other fields have information for reconstructing original datagram. Fragment offset gives original location of fragment.

Router has local MTU to computer size of each fragment. It puts part of data from original datagram in each fragment and puts other information into header. The fragmentation process is shown in the figure below.

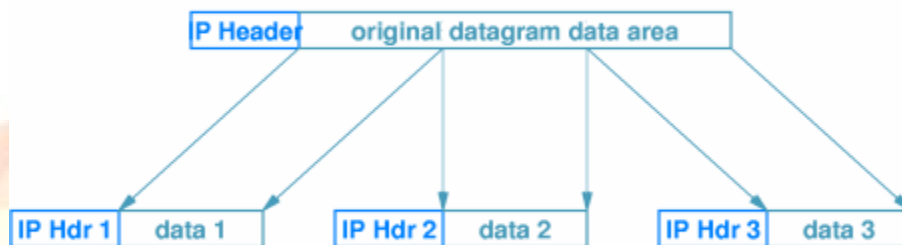

Figure 30.5

DATAGRAM REASSEMBLY:

Reconstruction of original datagram is called reassembly. Ultimate destination performs reassembly as shown below.



Figure 30.6

Fragments may arrive out of order. Header bit identifies fragments containing end of data from original datagram. In the figure 30.5 fragment 3 is identified as last fragment.

FRAGMENT IDENTIFICATION:

Let's see how fragments are associated with original datagram. IDENT field in each fragment matches IDENT field in original datagram. Fragments from different datagrams can arrive out of order and still be sorted out.

FRAGMENT LOSS:

IP may drop fragment because destination drops entire original datagram. Destination sets timer with each fragment to identify lost fragment. If timer expires before all fragments arrive, fragment is assumed lost and datagram is dropped. Source (application layer protocol) is assumed to retransmit.

FRAGMENTING A FRAGMENT:

Fragment may encounter subsequent network with even smaller MTU. Router fragments the fragment to fit. Resulting sub-fragments look just like original fragments (except for size). There is no need to reassemble hierarchically as sub-fragments include position in original datagram.

Lecture No. 31

THE FUTURE IP (IPV6)

INTRODUCTION:

The current version of IP- Version 4 (IPV4) is 20 years old. IPV4 has shown remarkable ability to move to new technologies. IETF has proposed entirely new version to address some specific problems.

SUCCESS OF IP:

IP has accommodated dramatic changes since original design. But basic principles are still appropriate today. There are many new types of hardware.

SCALING:

Scale is also dramatically changed. Size from a few tens to a few tens of millions of computers has been revolutionized. Speed has increased from 56Kbps to 1Gbps. Also there is an increased frame size in hardware.

MOTIVATION FOR CHANGE:

One of the parameters, which motivated IP for change is address space. The 32-bit address space allows for over a million networks. But most networks are class C and too small for many organizations. 214 class B network addresses already almost exhausted (and exhaustion was first predicted to occur, a couple of years ago).

The second parameter is type of service, the IP provides. Different applications have different requirements for delivery reliability and speed. Current IP has type of service that is not often implemented. Another factor for the motivation for change is multicast.

NAME AND VERSION NUMBER:

A preliminary version of IP was called IP- Next Generation (IPng). There were several proposals and all called IPng. One name was selected and it used next available version number i.e. 6. The result is IP version 6 (IPV6).

NEW FEATURES:

The new features of IPV6 are as follows:

- IPV6 addresses are 128 bits.
- Header format is entirely different.
- Additional information is stored in optional extension headers, followed by data.
- Flow label and quality of service allows audio and video applications to establish appropriate connections.
- New features can be added more easily. So it is extensible.

IPV6 DATAGRAM FORMAT:

It is shown in the figure below:

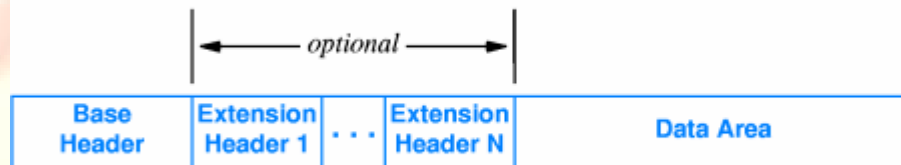

Figure: 31.1

IPV6 BASE HEADER FORMAT:

It contains less information than IPV4 header. Next header points to first extension header. Flow label is partitioned into a TRAFFIC CLASS field and a separate FLOW LABEL field used to identify a specific path through the network.

Routers use flow label to forward datagrams along prearranged path.
It is shown in the figure below:



Figure 31.2

IPV6 NEXT HEADER:

It is shown in the figure below:

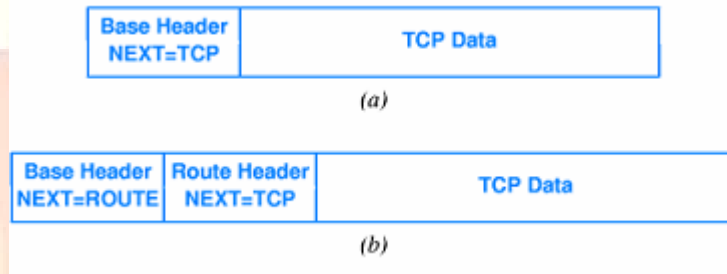

Figure 31.3

PARSING IPv6 HEADERS:

Base header is fixed size i.e. 40 octets. NEXT HEADER field in the base header defines type of header and it appears at end of fixed-size base header. Some extension headers are variable sized. NEXT HEADER field in extension header defines type. HEADER LEN field gives size of extension header as shown in the figure below:



Figure 31.4

Lecture No. 32

IPv6 AND AN ERROR REPORTING MECHANISM

FRAGMENTATION:

Fragmentation information is kept in separate extension header. Each fragment has base header and (inserted) fragmentation header. Entire datagram including original header may be fragmented. This process is shown in the figure below.

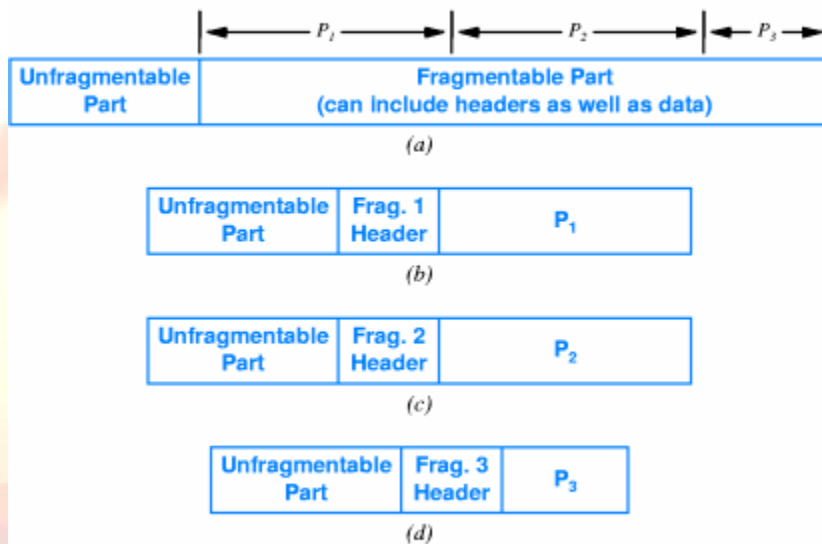

Figure 32.1

FRAGMENTATION AND PATH MTU:

IPv6 source (not intermediate routers) is responsible for fragmentation. Routers simply drop datagrams larger than network MTU (Maximum Transmission Unit). So source must fragment datagram to reach destination.

Source determines path MTU. The smallest MTU on any network between source and destination and it fragments datagram to fit within that MTU.

The process of learning the path MTU is known as path MTU discovery. Path MTU discovery is used. Source sends probe message of various sizes until destination reached. It must be dynamic i.e. path may change during transmission of datagrams.

USE OF MULTIPLE HEADERS:

It has following advantages:

- **Efficiency:** Header is only as large as necessary.
- **Flexibility:** it can add new headers for new features.
- **Incremental development:** It can add processing for new features to testbed, other routers will skip those headers.

IPv6 ADDRESSING:

IPv6 uses 128-bit addresses. A 128-bit address includes network prefix and host suffix. An advantage of IPv6 addressing is that it has no address classes i.e. prefix/suffix boundary can fall anywhere.

Following are special types of addresses, IPv6 uses:

- Unicast:** It is used for single destination computer.
Multicast: It is used for multiple destinations; possibly not at same site.
Cluster: This type of address is used for collection of computers with same prefix, datagram is delivered to one out of cluster.

IPv6 ADDRESS NOTATION:

128-bit addresses unwidely in dotted decimal; requires 16 numbers:
105.220.136.100.255.255.255.255.0.0.18.128.140.10.255.255

Groups of 16-bit numbers in hex separated by colons – colon hexadecimal (or colon hex).
69DC: 8864:FFFF: FFFF: 0:1280:8C0A:FFFF

Zero-compression – series of zeroes indicated by two colons

FF0C: 0:0:0:0:0:0:B1
FF0C::B1

IPv6 address with 96 leading zeros is interpreted to hold an IPv4 address.

AN ERROR REPORTING MECHANISM (ICMP)

INTRODUCTION:

IP provides best-effort delivery. Delivery problems can be ignored; datagrams can be 'dropped on the floor'. Internet Control Message Protocol (ICMP) provides error-reporting mechanism.

BEST-EFFORT SEMANTICS AND ERROR DETECTION:

Internet layer can detect a variety of errors: e.g.

- Checksum (header only)
- TTL expires
- No route to destination network.
- Can't deliver to destination host (e.g., no ARP reply).

Internet layer discards datagrams with problems. Some - for example, checksum error - can't trigger error messages.

INTERNET CONTROL MESSAGE PROTOCOL:

Some errors can be reported. Router sends message back to source in datagram. Message contains information about problem. It is encapsulated in IP datagram.

TYPES OF MESSAGES:

Internet control Message Protocol (ICMP) defines error and informational messages. These are given as follows:

1. ERROR MESSAGES:

These are as follows:

- Source quench
- Time exceeded
- Destination unreachable
- Redirect
- Fragmentation required

2. INFORMATIONAL MESSAGES:

These are as follows:

- Echo request/reply
- Address mask request /reply
- Router discovery



Lecture No. 33

AN ERROR REPORTING MECHANISM (ICMP)

ICMP MESSAGE TRANSPORT:

ICMP message transport is acted upon by getting ICMP encapsulated in IP. This is shown in the figure below:

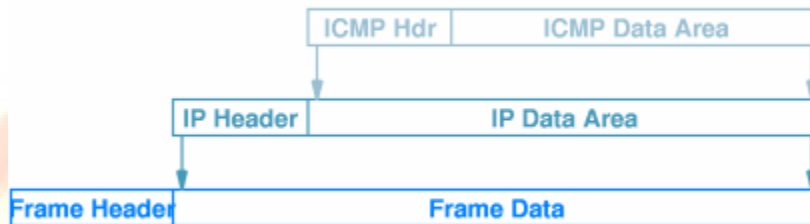

Figure 32.2

ICMP message is sent in response to incoming datagrams with problems. ICMP message is not sent for ICMP message.

USING ICMP TO TEST REACHABILITY:

ICMP can also be used to test different tools. An Internet host A, is reachable from another host B, if datagrams can be delivered from A to B. Ping program tests reachability. It sends datagram from B to A, that echoes back to B. It uses ICMP echo request and echo reply messages. Internet layer includes code to reply to incoming ICMP echo request messages.

USING ICMP TO TRACE A ROUTE:

List of all routers on path from A to B is called the route from A to B. The intermediate routers send ICMP time exceeded message to the source and destination sends an ICMP destination unreachable message to the source.

Tracert (Windows version) sends ICMP echo messages with increasing TTL. Router that decrements TTL to 0 sends ICMP time exceeded message, with router's address as source address. First, with TTL 1, gets to first router, which discards and sends time exceeded message. Next, with TTL 2 gets through first router to second router. It continues until an ICMP echo reply message from destination is received.

THE LAST ADDRESS PRINTED BY TRACE-ROUTE:

There are two possibilities used to detect the destination.

- Send an ICMP echo request, destination host will generate an ICMP echo reply.
- Send a datagram to a non-existent application, destination host will generate an ICMP destination unreachable message.

USING ICMP FOR PATH MTU:

Fragmentation should be avoided. Source can configure outgoing datagrams to avoid fragmentation. Source determines path MTU- smallest network MTU on path from source to destination. Source probes path using IP datagrams with don't fragment flag. Router responds with ICMP fragmentation required message. Source sends smaller probes until destination reached.

CS610-Computer Network FINAL TERM MCQS

Prepared by: JUNAID MALIK

AL-JUNAID TECH INSTITUTE



www.vulmshelp.com



Language Courses Training Available

I'm providing paid courses in different languages within 3 Months, Certificate will be awarded after completion.

- HTML
- CSS
- JAVASCRIPT
- BOOTSTRAPS
- JQUERY
- PHP MYSQL
- NODES.JS
- REACT JS

LMS Handling Services

LMS Activities Paid Task

Assignments 95% Results

Quizes 95% Results

GDB 95% Results

For CS619 Project Feel Free To Contact With Me

Ph# [0304-1659294](tel:0304-1659294)
Email: junaidfawal08@gmail.com

AL-JUNAID TECH INSTITUTE

ALL answers are verified if found any mistake then Correct ACCORDINGLY

- 1 Inside a computer, each address mask is stored as a ___ bit value.
 - a. 48
 - b. 64
 - c. 16
 - d. 32
- 2 The protocol address of the next hop must be _____ to an equivalent hardware address before a packets can be sent.
 - a. Encrypted
 - b. Decrypted
 - c. Translated
 - d. Segmented
- 3 TCP/IP define the term _____ to refer any computer system that connects to a network and runs applications for user.
 - a. Router
 - b. Host computer
 - c. Bridge
 - d. Switch
- 4 _____ protocols of TCP/IP layering model specify how to ensure reliable transfer.
 - a. Physical Layer
 - b. Network Interface Layer
 - c. Internet Layer
 - d. Transport Layer
- 5 _____ protocols of TCP/IP layering model specify how to organize data an how a computer translate frames over a network.
 - a. Session
 - b. Network Interface layer
 - c. Internet Layer
 - d. Transport Layer
- 6 _____ are two standard implementations to improve computational efficiency.
 - a. Hashing and Direct indexing
 - b. Segmentation and Fragmentation
 - c. Queuing and packetizing
 - d. Indexing and Framing
- 7 _____ of TCP/IP protocol suit defines the basic characteristics of network hardware
 - a. Physical Layer

AL-JUNAID TECH INSTITUTE

- b. Data link layer
- c. Internet Layer
- d. Transport Layer

8 Dotted Decimal represented each octet in ____ and uses a dot to separate octets.

- a. Binary
- b. **Decimal**
- c. Hexadecimal
- d. Octal

9 If the IP address ____ identifies the Physical Network to which the computer is attached.

- a. **Prefix**
- b. Suffix
- c. Mux
- d. Demux

10 Mapping between a protocol address and a hardware address is called _____.

- b. Segmentation
- c. Hashing
- c. **Address Resolution**

a. Fragmentation

11 _____ protocols of TCP/IP layering model specify how to organize data into frame and how a computer transmits frames over a network.

d. Session

b. Network Interface Layer

- a Internet Layer
- b Transport Layer

12 In Closed-form computation, the protocol address assigned to a computer is chosen carefully so that computer's hardware address can be computed from the protocol address using basic Boolean and _____ operations.

AL-JUNAID TECH INSTITUTE

a. Arithmetic

- a. XOR
- b. Shift
- c. XNOR

13 As the Internet grew, the original Classful addressing scheme became a limitation. The IP address space was being exhausted because all networks had to choose one of _____ possible sizes.

a. Three

- a. two
- b. four
- c. five

14 Dotted decimal notation is a syntactic form the IP software uses to express _____ binary values when interacting with humans.

- b. 8-bit
- c. 16-bit

c. 32-bit

- d. 64-bit

15 In the IP address _____ identifies an individual computer on the network.

- a. Prefix

b. Suffix

- b. Mux
- c. Demux

AL-JUNAID TECH INSTITUTE

16 Internet protocol (IP) address version 4 is comprised of -----bits.

b. 48

c. 32

d. 24

e. 128

17 A separate _____ table is used for each physical network.

b. bit-binding

c. Checksum

c. address-binding

d. CRC

18. Inside a computer, each address mask is stored as a _____ bit value.

c. 48

d. 64

e. 16

d. 32

19. Dotted decimal represents each octet in _____ and uses a dot to separate octets.

a. Binary

b. decimal

b. hexadecimal

c. Octal

20. _____ of TCP/IP Protocol Suit specifies the format of packets sent across

Internet as well as the mechanisms used to forward packets.

AL-JUNAID TECH INSTITUTE

- c. Physical Layer
- d. Data Link Layer

c. Internet Layer

- d. Transport Layer

21. The IP class scheme does not divide the _____ address space into equal size class and the classes do not contain the same number of networks.

- a. 16-bit

b. 32-bit

- c. 48-bit
- d. 64-bit

22. _____ of TCP/IP protocol suit defines the basic characteristics of network hardware.

c. Physical Layer

- d. Data Link Layer
- e. Internet Layer
- f. Transport Layer

23. The protocol address of the next hop must be _____ to an equivalent hardware address before a packet can be sent.

- b. Encrypted
- c. Decrypted

c. Translated

AL-JUNAID TECH INSTITUTE

d. Segmented

24. Address Resolution Protocol is mostly used to bind a 32-bit IP address to a

_____ Ethernet address.

a. 16-bit

b. 48-bit

a. 64-bit

b. 128-bit

25. TCP/IP defines the term _____ to refer any computer system that

connects to a network and runs applications for users.

a. Router

b. Host computer

c. Bridge

d. Switch

26. _____ are two standard implementations to improve computational

efficiency.

a. Hashing and Direct indexing

AL-JUNAID TECH INSTITUTE

b. Segmentation and Fragmentation

c. Queuing and Packetizing

d. Indexing and Framing

27. A ----- Relies on the hardware manufacturer to assign a unique physical address to each network interface.

▶ Static addressing scheme (Page 34)

▶ Configurable addressing scheme

▶ Dynamic addressing scheme

▶ None of the given

28. An interface for thin Ethernet must have an _____ connector, and must generate signals according to the _____ specification.

▶ RJ-45, 10 Base T

▶ RJ-45, 10 Base 5

▶ BNC, 10 Base 2 (Page 21)

▶ BNC, 10 Base T

29. A system with redundant bridges might have a problem with _____ in the system.

▶ Loop (page 50)

▶ Filters

▶ Spanning Trees

▶ All given choices

30. A Bridge can _____

▶ Filter a frame

▶ Forward a frame

▶ Extend a LAN

▶ Do all (page 50)

31. _____ is used for typical data applications (where the data rate may be unknown and bursty) and allows use of whatever bandwidth is available at a given time.

▶ Constant Bit Rate (CBR) service

▶ Variable Bit Rate (VBR) service

AL-JUNAID TECH INSTITUTE

▶ Available Bit Rate (ABR) service (Page 71)

▶ None of the given

32. ATM assigns each VC a _____ identifier that is divided two parts to produce a hierarchy.

▶ 21-bit

▶ 22-bit

▶ 23-bit

▶ 24-bit (Page 67)

33. _____ of TCP/IP layering model, corresponds to basic network hardware.

▶ Physical Layer (Page 84)

▶ Network Interface Layer

▶ Internet Layer

▶ Transport Layer

34. _____ places the boundary between the second and third octets

▶ Class A

▶ Class B (page 86)

▶ Class C

▶ Class D

35. UDP and TCP are both _____ layer protocols

▶ Physical

▶ Data link

▶ Network

▶ Transport (Page 101)

36. Connection-oriented service, Point-to-point, Complete reliability, Full-duplex communication, Stream interface, Reliable connection startup and Graceful connection shutdown are the services provided by-----.

▶ IP

▶ None of the given

▶ TCP (Page 123)

AL-JUNAID TECH INSTITUTE

▶ UDP

37. _____ protocols of TCP/IP layering model specify how to ensure reliable transfer.

▶ Physical Layer

▶ Network Interface Layer

▶ Internet Layer

▶ Transport Layer (Page 84)

38. _____ identifies which application program on receiving computer should receive the data

▶ Logical address

▶ Source port

▶ Destination Port (google)

▶ None of the given

39. _____ identifies the application program that sent the data.

▶ Destination Port

▶ Source port (google)

▶ Logical address

▶ None of the given

40. Which of the following are interior routing protocols?

▶ RIP

▶ OSPF

▶ BGP

▶ RIP and OSPF (page 137)

41. The Border Gateway Protocol (BGP) uses _____ for all communication

▶ UDP

▶ TCP (page 138)

▶ Both UDP and TCP

▶ None of the given

AL-JUNAID TECH INSTITUTE

42. _____ measures distance in network hops, where each network between the source and destination counts as single hop.

▶ BGP

▶ OSPF

▶ RIP (Page 138)

▶ None of the given

43. OSPF is based on _____

▶ Distance vector routing

▶ Link state routing (Page 140)

▶ Path vector routing

▶ Distance vector routing and Link state routing

44. _____ performs local multicast and uses IP-in-IP encapsulation to send multicast datagrams from one site on the Internet to another.

▶ Distance Vector Multicast Routing Protocol (DVMRP) (Page 144)

▶ Core Based Trees (CBT)

▶ Protocol Independent Multicast _ Sparse Mode (PIM-SM)

▶ Protocol Independent Multicast _ Dense Mode (PIM-DM)

45. The length of time required to send a variable length packet is variable and does not require a complicated interrupt scheme to detect completion of transmission.

▶ True

▶ False (Page 72)

46. NEXT HEADER field in the base header defines type of header and it appears at end of fixed-size base header.

▶ True (Page 112)

▶ False

47. Although message exchange can be used to bind addresses, sending a request for each binding is hopelessly inefficient.

▶ True (Page 99)

▶ False

AL-JUNAID TECH INSTITUTE

48. Address mask defines how many bits of address are in suffix.

▶ True

▶ False (Page 103)

49. A computer attached to a given network can only communicate with other computers attached to the same network. Is this a problem with multiple networks?

▶ True (Page 81)

▶ False

50. In the 1970s large organizations began to acquire multiple networks. Each network in the organization formed island. Employees needed to choose a computer appropriate for each task. So they needed multiple screens, keyboards and computers.

▶ False

▶ True (Page 81)

51. The term self-identifying is used for Classful IP addresses because the class of the address can be computed from the address_____.

▶ itself (Page 87)

▶ prefix

▶ suffix

▶ mask

52. In which method of Address Resolution Protocol the protocol address independent of hardware address? Were "T" stands for Table lookup, "C" for Closed-form Computation and "D" for Data Exchange?

▶ T, C

▶ D

▶ C

▶ T, D (Page 97)

53. In which method of Address Resolution Protocol the protocol address is determined by hardware address? Were "T" stands for Table lookup, "C" for Closed-form Computation and "D" for Data Exchange?

▶ T

▶ D

▶ C (Page 97)

AL-JUNAID TECH INSTITUTE

▶ T, C 6

54. Reconstruction of original datagram is called reassembly.

▶ True (Page 28)

▶ False

55. A computer needs a complete stack of protocols to run either a client or a server.

▶ True)

▶ False

56. TCP uses _____ mechanism to control the flow of data.

▶ door

▶ window (Page 126)

▶ acknowledgment

▶ retransmission FINALTERM EXAMINAT

57. In Direct point to point communication adding the Nth computer requires----- new connections.

▶ None of the given

▶ N 2

▶ N-1 (Page 23)

▶ $(N^2 - N)/2$

58. In -----, network occupies the smaller area like a room a floor or a building

▶ LAN (Page 4)

▶ WAN

▶ MAN

▶ None of the given 7

59. The third field of the header consists of ----- bit Ethernet frame type.

▶ 48

▶ 32

▶ 16 (google)

▶ 8

AL-JUNAID TECH INSTITUTE

60. The maximum size of an Ethernet segment is _____

- ▶ 250 meters
- ▶ 500 meters (google)
- ▶ 700 meters
- ▶ None of the given

61. The network with Throughput T and Delay D has a total ----- bits in transit at a time.

- ▶ $D + T$
- ▶ $D - T$
- ▶ $D \times T$
- ▶ D / T

62. _____ places the boundary between the first and second octets

- ▶ Class A (page 86)
- ▶ Class B
- ▶ Class C
- ▶ Class D

63. Router detects datagram ----- than network MTU and then it splits into pieces and each piece is -----than outbound network MTU.

- ▶ Larger, smaller (Page 108)
- ▶ Larger, larger
- ▶ Smaller, larger
- ▶ Smaller, smaller

64. Connectionless service, Message-Oriented protocol, best-effort delivery service, arbitrary interaction & operating system independent are the characteristics of _____

- ▶ TCP
- ▶ UDP (Page 120)
- ▶ IP
- ▶ None of the given

AL-JUNAID TECH INSTITUTE

65. ----- provide Application to application communication it also called end to end communication

▶ IP

▶ TP (Page 119)

▶ RIP

▶ None of the given

66. A routing table contains _____

▶ The destination network ID

▶ The hop count to reach the network

▶ The router ID of the next hop (Page 102)

▶ All of the given

67. Which of the following protocols allows the sender and receiver to enforce policies.

▶ RIP

▶ OSPF

▶ BGP (page 138)

▶ RIP and OSPF

68. _____ measures distance in network hops, where each network between the source and destination counts as single hop.

▶ BGP

▶ OSPF

▶ RIP (Page 138)

▶ None of these

69. _____ includes a 32-bits address mask with each address, which allows the address to be classful, classless, or subnetted.

▶ RIP

▶ OSPF (Page 140)

▶ BGP

▶ None of the given 9

AL-JUNAID TECH INSTITUTE

70. One repeater -----, two repeaters ----- the maximum cable length limitation.

▶ Double, triple (Page 49)

▶ Double, 4 time

▶ half, triple

▶ Double, half

71. ICMP message transport is acted upon by getting ICMP encrypted in IP.

▶ True (Page 117)

▶ False

72. Like most application programs, a client and server use a transport protocol to communicate.

▶ True (Page 146)

▶ False

73. Mapping between a protocol address and a hardware address is called Address Resolution.

▶ True (Page 93)

▶ False

74. Address mask defines how many bits of address are in suffix?

▶ True

▶ False (Page 103)

75. A single networking technology is best for all needs.

▶ True

▶ False (Page 81)

76. In the 1970s large organizations began to acquire multiple networks. Each network in the organization formed island. Employees needed to choose a computer appropriate for each task. So they needed multiple screens, keyboards and computers.

▶ False

▶ True (Page 81)

77. Router detects datagram-----than network MTU

AL-JUNAID TECH INSTITUTE

▶ Larger (Page 108)

▶ Smaller

▶ None of given

▶ Equal

78. Information can flow in either or both direction between

▶ Clients

▶ Clients and servers

▶ Servers

▶ None of given

79. One of the design goals for unicast route propagation is _____.

▶ consistency

▶ inconsistency

▶ stability

▶ dynamic addressing

80. IPV6 address consists of _____

▶ 32 Bits

▶ 64 Bits

▶ 128 Bits (Page 128)

▶ none of the given

81. UDP offers application programs a Message-Oriented Interface, applications can depend on protocol to preserve data boundaries.

▶ True (Page 120)

▶ False

82. In case TCP, retransmission, acknowledgment from a computer on LAN are expected to arrive within

▶ Seconds

▶ Micro seconds

▶ Milliseconds

AL-JUNAID TECH INSTITUTE

▶ Nanoseconds

83. Twice NAT is another variant of NAT. it is used with site that runs server. In this process NAT box is connected to Domain Name.

▶ True (Page 131)

▶ False

84. A network uses a -----arranges for computers to be connected in a closed loop.

▶ Star Topology

▶ Ring Topology (Page 25)

▶ Bus Topology

▶ None of the given

85. Protocol addresses are abstractions provided by _____.

▶ hardware

▶ software (Page 93)

▶ operating system

▶ internet

86. In Direct point to point communication adding the Nth computer requires----- new connections.

▶ None of the given

▶ N2

▶ N-1 (Page 23)

▶ (N2 -N)

87. In Point-to-Point topology there are two topologies.

▶ Tree and Ring

▶ Star and Ring

▶ Star and Tree (Page 5)

▶ None of the given

88. In -----, network occupies the smaller area like a room a floor or a building

▶ LAN (Page 4)

AL-JUNAID TECH INSTITUTE

- ▶ WAN
- ▶ MAN
- ▶ None of the given

89. CRC can detect more errors than a simple checksum.

- ▶ true (page 80)
- ▶ false

90. The Gigabit Ethernet hardware operates at a rate of -----

- ▶ 10 Mbps
- ▶ 100 Mbps
- ▶ 1000 Mbps
- ▶ None of the given

91. Formally named _____ informally known as the twisted pair Ethernet or TP Ethernet.

- ▶ 10 Base 2
- ▶ 10 Base 5
- ▶ 10 Base T (Page 43)
- ▶ None of the given

92. An interface for thin Ethernet must have an _____ connector , and must generate signals according to the _____ specification.

- ▶ RJ-45, 10 Base T
- ▶ RJ-45, 10 Base 5
- ▶ BNC, 10 Base 2 (Page 201)
- ▶ BNC, 10 Base T

93. _____ computes shortest paths in a graph by using weights on edges as a measure of distance.

- ▶ Greedy algorithm
- ▶ Distance vector algorithm
- ▶ Dijkstra's algorithm (page 112)
- ▶ None of the given

AL-JUNAID TECH INSTITUTE

94. Basic LAN technologies such as Ethernet, Token Ring, and FDDI use a _____.

▶ Connectionless service paradigm (page 112)

▶ Connection-oriented service paradigm

▶ Both Connectionless and Connection-oriented service paradigm

▶ None of the given

95. _____ protocol of TCP/IP layering model specify how to ensure reliable transfer.

▶ Physical Layer

▶ Network Interface Layer

▶ Internet Layer

▶ Transport Layer (Page 84)

96. An Internet Address (IP address) is a unique _____ binary number assigned to a host and used for all communication with host

▶ 48-bit

▶ 32-bit (Page 85)

▶ 24-bit

▶ None of the given

97. The address _____ identifies the physical network to which the computer is attached, while the _____ identifies an individual computer on that network.

▶ prefix , suffix (Page 85)

▶ suffix , prefix

▶ suffix , suffix

▶ None of the given

98. _____ places the boundary between the first and second octets

▶ Class A

▶ Class B (page 88)

▶ Class C

▶ Class D

AL-JUNAID TECH INSTITUTE

99. _____ places the boundary between the third and fourth octets.

- ▶ Class A
- ▶ Class B
- ▶ Class C (page 88)
- ▶ Class D

100. _____ field of header indicates whether a datagram is a fragment or a complete datagram.

- ▶ **FLAGS**
- ▶ FLAGMENT OFFSET
- ▶ IDENTIFICATION
- ▶ None of the given

101. _____ provides connectionless service.

- ▶ TCP
- ▶ **UDP (Page 120)**
- ▶ IP
- ▶ None of the given

102. UDP and TCP are both _____ layer protocols

- ▶ Physical
- ▶ Data link
- ▶ Network
- ▶ **Transport (Page 101)**

103. Connection-oriented service, Point-to-point, Complete reliability, Full-duplex communication, Stream interface, Reliable connection startup and Graceful connection shutdown are the services provided by _____

- ▶ IP
- ▶ None of the given
- ▶ **TCP (Page 123)**
- ▶ UDP

AL-JUNAID TECH INSTITUTE

104. _____ identifies which application program on receiving computer should receive the data

- ▶ Logical address
- ▶ Source port
- ▶ Destination Port
- ▶ None of the given

105. _____ identifies the application program that sent the data.

- ▶ Destination Port
- ▶ Source port
- ▶ Logical address
- ▶ None of the given

106. The Border Gateway Protocol (BGP) uses _____ for all communication

- ▶ UDP
- ▶ TCP (page 138)
- ▶ Both UDP and TCP
- ▶ None of the given

107. Protocol addresses are abstractions provided by _____.

- ▶ hardware
- ▶ software (Page 93)
- ▶ operating system
- ▶ internet

108. These packets serve same purpose on _____ as frames on _____

- ▶ Intranet, LAN
- ▶ Internet, WAN
- ▶ Intranet, WAN
- ▶ Internet, LAN (Page 101)

109. Address mask defines how many bits of address are in suffix?

- ▶ True

AL-JUNAID TECH INSTITUTE

▶ False (Page 103)

110. A single networking technology is best for all needs.

▶ True

▶ False (Page 81)

111. A computer attached to a given network can only communicate with other computers attached to the same network. Is this a problem with multiple networks?

▶ True (Page 81)

▶ False

112. The term self-identifying is used for Class full IP addresses because the class of the address can be computed from the address_____.

▶ itself (Page 87)

▶ prefix

▶ suffix

▶ mask

113. Find the class of the address. 10100111 11011011 10001011 01101111

▶ A

▶ B (page86)

▶ E

▶ C

114. Find the class of the address: 11110011 10011011 11111011 00001111

▶ A

▶ C

▶ E (page86)

▶ B

115. In which method of Address Resolution Protocol the protocol address is determined by hardware address? Were "T" stands for Table lookup, "C" for Closed-form Computation and "D" for Data Exchange?

▶ T

AL-JUNAID TECH INSTITUTE

▶ D

▶ C (Page 97)

▶ T, C

116. Which method of Address Resolution Protocol requires hardware broadcast? Were "T" stands for Table lookup, "C" for Closed-form Computation and "D" for Data Exchange?

▶ D (Page 97)

▶ T

▶ C

▶ T, D

117. Which method of Address Resolution Protocol resolution with minimum delay? Were "T" stands for Table lookup, "C" for Closed-form Computation and "D" for Data Exchange?

▶ T, D

▶ C

▶ T

▶ T, C (Page 97)

118. In which method of Address Resolution Protocol the implimentation is more difficult? Were "T" stands for Table lookup, "C" for Closed-form Computation and "D" for Data Exchange?

▶ T, C

▶ T

▶ C

▶ D (Page 97)

119. On of the design goals for unicast route propagation is _____.

▶ Consistency

▶ inconsistency

▶ stability (Computer Networks and Internets, page 344) rep

▶ dynamic addressing

AL-JUNAID TECH INSTITUTE

120. Propagation multicast routing information differs dramatically from unicast route propagation?

▶ True (Computer Networks and Internets, page 335)

▶ False

121. To save traffic, an EGP does not summarize routing information from the autonomous system before passing it to another autonomous system.

▶ True

▶ False

122. In IPv6 the type of address used for collection of computers with same prefix. Are known as _____.

▶ Unicast

▶ Multicast

▶ None of the given (Page 114)

123. Special types of addresses in IPv6 used for multiple destinations; possibly not at same site. Are known as _____.

▶ Unicast

▶ Anycast

▶ Multicast (Page 114)

▶ None of the given

124. UDP offers application programs a Message-Oriented Interface, applications can depend on protocol to preserve data boundaries.

▶ True (Page 120)

▶ False

125. Reliability is the responsibility of the _____ layer

▶ Network

▶ Data link

▶ Transport (Page 123)

▶ Application

126. FDDI can transmit data at a rate of -----

AL-JUNAID TECH INSTITUTE

▶ 100 million bits per second (Page 31)

- ▶ 10 million bits per second
- ▶ 1000 million bits per second
- ▶ None of the given

127. Computer networks are often called ----- because they use packet technology.

- ▶ Ethernet
- ▶ Switch networks
- ▶ Packet networks
- ▶ None of the given

128. A network uses a -----arranges for computers to be connected in a closed loop.

- ▶ Star Topology
- ▶ Ring Topology (Page 25)

- ▶ Bus Topology 22
- ▶ None of the given

129. An -----method, the network hardware designers specify how type information is included in the frame and the value use to identify various frame types.

- ▶ Explicit frame type
- ▶ Ideal frame type
- ▶ Implicit frame type
- ▶ None of the given

130. An interface for thin Ethernet must have an _____ connector , and must generate signals according to the _____ specification.

- ▶ RJ-45, 10 Base T
- ▶ RJ-45, 10 Base 5

▶ BNC, 10 Base 2 (Page 201)

- ▶ BNC, 10 Base T

131. A Bridge forwards or filters a frame by comparing the information in its address table to the frame's _____

- ▶ Layer 2 source address

AL-JUNAID TECH INSTITUTE

▶ Source node's physical address

▶ Layer 2 destination address

▶ Layer 3 destination address

132. _____ protocol of TCP/IP layering model specify how to ensure reliable transfer.

▶ Physical Layer

▶ Network Interface Layer

▶ Internet Layer

▶ Transport Layer (Page 84)

133. When an application----- data, it makes a copy of the data available to all other computers on the network.

▶ **Broadcasting**

▶ Multicasting

▶ Unicasting

▶ None of the given

134. Ethernet uses a ----- bit static addressing scheme in which each device is assigned a unique address by the manufacturer.

▶ 64

▶ 48

▶ 32

▶ 8

135. The product of delay and throughput measures the _____ of data that can be present on the network.

▶ Area

▶ **Volume(google)**

▶ Length

AL-JUNAID TECH INSTITUTE

- ▶ None of the given

136. Connectionless service, Message-Oriented protocol, best effort delivery service, arbitrary interaction and operating system independent are the characteristics of _____

- ▶ TCP

- ▶ **UDP (page 120)**

- ▶ IP

- ▶ None of the given

137. -----serve same purpose in internet as frames on LAN.

- Virtual frames

- Packet

- A and b both

- **Virtual packets (page 101)**

138. A ----- relies on the hardware manufacturer to assign a unique physical address to each network interface.

- ▶ **Static addressing scheme (page 133)**

- ▶ Configurable addressing scheme

- ▶ Dynamic addressing scheme

139. ▶ None of the given

An interface for thin Ethernet must have an _____ connector , and must generate signals according to the _____ specification.

- ▶ **RJ-45, 10 Base T**

- ▶ RJ-45, 10 Base 5

- ▶ BNC, 10 Base 2

- ▶ BNC, 10 Base T

140. A system with redundant bridges might have a problem with _____ in the system.

- ▶ **Loop**

- ▶ Filters

- ▶ Spanning Trees

- ▶ All given choices

AL-JUNAID TECH INSTITUTE

141. A Bridge can _____

- ▶ Filter a frame
- ▶ Forward a frame
- ▶ Extend a LAN
- ▶ Do all the above (page 50)

142. _____ is used for typical data applications (where the data rate may be unknown and bursty) and allows use of whatever bandwidth is available at a given time.

- ▶ Constant Bit Rate (CBR) service
- ▶ Variable Bit Rate (VBR) service
- ▶ Available Bit Rate (ABR) service (page 71)
- ▶ None of the given

143. ATM assigns each VC a _____ identifier that is divided into two parts to produce a hierarchy.

- ▶ 21-bit
- ▶ 22-bit
- ▶ 23-bit
- ▶ 24-bit

144. _____ of TCP/IP layering model, corresponds to basic network hardware.

- ▶ Physical Layer (page 123)
- ▶ Network Interface Layer
- ▶ Internet Layer
- ▶ Transport Layer

145. _____ places the boundary between the second and third octets

- ▶ Class A
- ▶ Class B
- ▶ Class C
- ▶ Class D

AL-JUNAID TECH INSTITUTE

146. UDP and TCP are both _____ layer protocols

- ▶ Physical
- ▶ Data link
- ▶ Network

▶ Transport (123 page)

147. _____ protocols of TCP/IP layering model specify how to ensure reliable transfer.

- ▶ Physical Layer
- ▶ Network Interface Layer
- ▶ Internet Layer

▶ Transport Layer (page 124)

148. _____ identifies which application program on receiving computer should receive the data

- ▶ Logical address
- ▶ Source port

▶ Destination port

▶ None of the given

149. _____ identifies the application program that sent the data.

▶ Destination Port

▶ Source port

▶ Logical address

▶ None of the given

150. _____
Which of the following are interior routing protocols?

▶ RIP (page 138)

- ▶ OSPF
- ▶ BGP
- ▶ RIP and OSPF

151. The Border Gateway Protocol (BGP) uses _____ for all communication

▶ UDP

AL-JUNAID TECH INSTITUTE

▶ TCP (138 page)

▶ Both UDP and TCP

▶ None of the given

152. Class A mask is 255.0.0.0 which is used for-----.

- ❖ All of the given option
- ❖ Unicasting
- ❖ Subnetting (page 103)
- ❖ Multicasting

153. _____
OSPF is based on-----

▶ Distance vector routing

▶ Link state routing (page 140)

▶ Path vector routing

▶ Distance vector routing and Link state routing

154. _____
_____ performs local multicast and uses IP-in-IP encapsulation to send multicast datagrams from one site on the Internet to another.

▶ Distance Vector Multicast Routing Protocol (DVMRP) (page 144)

▶ Core Based Trees (CBT)

▶ Protocol Independent Multicast _ *Sparse Mode* (PIM-SM)

▶ Protocol Independent Multicast _ *Dense Mode* (PIM-DM)

155. The length of time required to send a variable length packet is variable and does not require a complicated interrupt scheme to detect completion of transmission.

▶ True

▶ False

156. _____
NEXT HEADER field in the base header defines type of header and it appears at end of fixed-size base header.

▶ True(112 page)

▶ False

157. _____
Although message exchange can be used to bind addresses, sending a request for each binding is hopelessly inefficient.

▶ True

AL-JUNAID TECH INSTITUTE

▶ False

158. Address mask defines how many bits of address are in suffix?

▶ True

▶ False

159. A computer attached to a given network can only communicate with other computers attached to the same network. Is this a problem with multiple networks?

▶ True

▶ False

160.

_____ In the 1970s large organizations began to acquire multiple networks. Each network in the organization formed island. Employees needed to choose a computer appropriate for each task. So they needed multiple screens, keyboards and computers.

▶ False

▶ True (page 88)

161.

_____ The term self-identifying is used for Classful IP addresses because the class of the address can be computed from the address_____.

▶ itself (page 85)

▶ prefix

▶ suffix

▶ mask

162.

_____ In which method of Address Resolution Protocol the protocol address independent of hardware address?

▶ T, C

▶ D

▶ C

▶ T, D (page 97)

163.

_____ In which method of Address Resolution Protocol the protocol address is determined by hardware address?

AL-JUNAID TECH INSTITUTE

▶ T

▶ D

▶ C (page 97)

▶ T, C

164. _____
Reconstruction of original datagram is called reassembly.

▶ True

▶ False

165. A computer needs a complete stack of protocols to run either a client or a server.

▶ True

▶ False

166. When an application----- data, it makes a copy of the data available to all other computers on the network.

▶ **Broadcasting**

▶ Multicasting

▶ Unicasting

▶ None of the given

167. Ethernet uses a ----- bit static addressing scheme in which each device is assigned a unique address by the manufacturer.

▶ 64

▶ 48

▶ 32

▶ 8

168. The product of delay and throughput measures the _____ of data that can be present on the network.

▶ Area

AL-JUNAID TECH INSTITUTE

▶ Volume

- ▶ Length
- ▶ None of the given

169. Connectionless service, Message-Oriented protocol, best effort delivery service, arbitrary interaction and operating system independent are the characteristics of _____

- ▶ TCP

▶ UDP

- ▶ IP
- ▶ None of the given

170. _____ uses distance vector approach to define routing

- ▶ BGP
- ▶ OSPF

▶ RIP

- ▶ None of the given

171. Whenever it handles a packet, IP software needs to separate the destination address into a _____ and _____.

- ▶ postfix, Infix
- ▶ none of these
- ▶ Infix, prefix

▶ prefix, suffix

172. ARP is almost always used to bind a ___-bit IP address to a ___-bit Ethernet address.

AL-JUNAID TECH INSTITUTE

- ▶ 24, 32
- ▶ 32, 64
- ▶ 32, 128

173. Which method of Address Resolution Protocol is useful with any hardware?

- ▶ T
- ▶ **C (page 97)**
- ▶ D
- ▶ C, D

174. In which method of Address Resolution Protocol the protocol address is determined by hardware address?

- ▶ T
- ▶ D
- ▶ **C (page 97)**
- ▶ T, C

175. We use the term _____ to refer to a measure of the path that routing software use when choosing a route.

- ▶ routing path
- ▶ **routing metric**
- ▶ routing
- ▶ switching

176. A network uses a -----arranges for computers to be connected in a closed loop.

- ▶ Star Topology
- ▶ **Ring Topology**
- ▶ Bus Topology
- ▶ None of the given

AL-JUNAID TECH INSTITUTE

177. An interface for thin Ethernet must have an _____ connector , and must generate signals according to the _____ specification.

▶ **RJ-45, 10 Base T**

▶ RJ-45, 10 Base 5

▶ BNC, 10 Base 2

▶ BNC, 10 Base T

178. _____ protocols of TCP/IP layering model specify how to ensure reliable transfer.

▶ Physical Layer

▶ Network Interface Layer

▶ Internet Layer

▶ **Transport Layer**

179. _____ uses distance vector approach to define routing

▶ BGP

▶ OSPF

▶ **RIP**

▶ None of the given

180. _____ is ideal in a situation where the group is small and all members are attached to contiguous Local Area Networks.

❖ **Flood-and -Prune**

❖ Configuration-and -Tunneling

❖ Core-Based Discovery

❖ None of the given

181. Router that decrements TTL to ___ sends ICMP time exceeded message, with router s address as source address

❖ 3

❖ 2

❖ 1

AL-JUNAID TECH INSTITUTE

❖ **o**

182. Protocol addresses are abstractions provided by _____.

❖ hardware

❖ **software**

❖ internet

183. Although message exchange can be used to bind addresses, sending a request for each binding is hopelessly inefficient.

❖ **True**

❖ False

184. Which method of Address Resolution Protocol is useful with any hardware?

Were "T" stands for Table lookup, "C" for Closed-form Computation and "D" for Data Exchange?

❖ **T** (97 page)

❖ C

❖ D

❖ C, D

185. In which method of Address Resolution Protocol the implimentation is more difficult?

Were "T" stands for Table lookup, "C" for Closed-form Computation and "D" for Data Exchange?

❖ T, C

❖ T

C

❖ **D** (page 97)

186. To save traffic, an EGP does not summerize routing information from the autonomous system before passing it to another autonomous system.

❖ True

❖ **False**

187. ----- was especially concerned about the lack of high powered computers.

❖ IEEE

❖ APRA

❖ EIA

❖ **None**

188. Missing eot indicates sending computer crashed in frame format.

AL-JUNAID TECH INSTITUTE

❖ **True**

❖ False

189. The -----term refers to the general concept of a small block of data.

❖ **Packets**

Data

❖ Frame

❖ None of given

190. CRC can detect more errors than a simple checksum.

❖ **True**

❖ False

191. The network that uses a -----, usually consist of a single long cable to which computer attach.

❖ Star topology

❖ **Bus topology** (page 30)

❖ Ring topology

❖ None of the given

192. LAN that use ATM technology have a -----

❖ Star topology

❖ Bus topology

❖ Ring topology

❖ **None of the given** (page 31)

193. ----- has a jitter zero

❖ Virtual Private Network

❖ **Isochronous Network**

❖ Asynchronous Network

❖ None of the given

194. The network with Throughput T and Delay D has a total ----- bits in transit at a time.

❖ $D + T$

❖ $D - T$

❖ **D X T**

❖ D / T

195. One repeater -----, two repeaters ----- the maximum cable length limitation.

❖ **Double, triple**

❖ Double, 4 time

❖ half, triple

AL-JUNAID TECH INSTITUTE

❖ Double, half

196. End-to-end delivery service is connection oriented.

❖ True

❖ **False**

197. A single networking technology is best for all needs.

❖ True

❖ **False**

198. Twice NAT allows a site to run servers.

❖ **True**

❖ False

199. _____ device is used for multicasting.

❖ Hub

❖ Switch

❖ **Router**

❖ none of the given

200. _____ does not depend on any particular unicast routing protocol.

❖ PIM-DM

❖ **PIM-SM**

❖ PIM-AM

❖ none of the given

201. A routing table contains _____

❖ The destination network ID

❖ The hop count to reach the network

❖ **The router ID of the next hop**

❖ All of the given

202. _____ can be used to propagate information about remote networks.

❖ **Dynamic routing (page134)**

❖ Static routing

❖ Address resolution

❖ None of the given

203. _____ protocol is designed to use within an organization.

❖ OSPF

❖ MEOSPF

❖ **MOSPF (page 139)**

❖ none of the given

204. NAPT stands for _____

AL-JUNAID TECH INSTITUTE

❖ Network Address and Protocol Translation

❖ **Network Address and Port Translation** (page 132)

❖ Network Address and Packet Translation

❖ None of the given

205. In dynamic routing, the routing table is initialized when system boots.

❖ **True** (page 134)

❖ False

206. OSPF includes _____ address mask with each address.

❖ 30Bit

❖ **32Bit** (page 140)

❖ 34Bit

❖ none of the given

207. Twice NAT fails if an application uses the IP addresses instead of Domain Name.

❖ **True**(page 132)

❖ False

208. _____ uses window mechanism to control the flow of data.

❖ IP

❖ UDP

❖ **TCP** (page 128)

❖ none of the given

209. TCP uses _____ mechanism to control the flow of data.

❖ door

❖ **window** (page 122)

❖ acknowledgment

❖ retransmission

210. IGPs stand for _____

❖ Internal Gateway Protocols

❖ **Interior Gateway Protocols** (page 135)

❖ Intermediate Gateway Protocols

❖ None of the given

211. _____ protocol uses distance vector algorithm.

❖ IGP

❖ BGP

❖ **RIP** (page 139)

❖ None of the given

AL-JUNAID TECH INSTITUTE

212. _____ measures distance in network hops, where each network between the source and destination counts as single hop.

- ❖ BGP
- ❖ OSPF

❖ **RIP (page 138)**

- ❖ None of these

213. Network Address Translation (NAT) requires device to perform packet translation.

❖ **True (page 128)**

- ❖ False

214. We use the term _____ to refer to a measure of the path that routing software use when choosing a route.

- ❖ routing path

❖ **routing metric(page 132)**

- ❖ routing
- ❖ switching

215. Part of the 3-way handshake used to create a connection, requires each end to generate a random _____ sequence number.

❖ **32 bit**

- ❖ 16 bit
- ❖ 8 bit
- ❖ 64 bit

216. Reconstruction of original datagram is called reassembly.

❖ **True**

- ❖ False

217. Reliability is the responsibility of the _____ layer.

❖ **Transport**

- ❖ Network
- ❖ Physical
- ❖ Internet

218. _____ is ideal in a situation where the group is small and all members are attached to contiguous Local Area Networks.

❖ **Flood-and -Prune (page 123)**

- ❖ Configuration-and -Tunneling
- ❖ Core-Based Discovery
- ❖ None of the given

219. In Direct point to point communication adding the Nth computer requires----
----- new connections.

AL-JUNAID TECH INSTITUTE

❖ None of the given

❖ N^2

❖ **$N-1$**

❖ $(N^2 - N)/2$

220. The number of connections needed for N computer in direct point to point communication is equal to:

❖ **$(N^2 - N)/2$**

❖ $N(N-1)$

❖ N^2

❖ None of the given

221. Hardware that calculates a CRC uses two simple components.

❖ AND unit and XOR unit

❖ **Shift register and XOR unit (page 20)**

❖ Shift register and AND unit

❖ None of the given

222. The Gigabit Ethernet hardware operates at a rate of -----

❖ 10 Mbps

❖ 100 Mbps

❖ **1000 Mbps (page 46)**

❖ None of the given

223. Basic LAN technologies such as Ethernet, Token Ring, and FDDI use a _____.

❖ **Connectionless service paradigm**

❖ Connection-oriented service paradigm

❖ Both Connectionless and Connection-oriented service paradigm

❖ None of the given

224. An Internet Address (IP address) is a unique _____ binary number assigned to a host and used for all communication with host

❖ 48-bit

❖ **32-bit (page 85)**

❖ 24-bit

❖ None of the given

225. The address _____ identifies the physical network to which the computer is attached, while the _____ identifies an individual computer on that network.

❖ **prefix , suffix (page 85)**

❖ suffix , prefix

❖ suffix , suffix

AL-JUNAID TECH INSTITUTE

- ❖ None of the given

226. _____ Field of header indicates whether a datagram is a fragment or a complete datagram.

- ❖ **FLAGS**

- ❖ FLAGMENT OFFSET

- ❖ IDENTIFICATION

- ❖ None of the given

227. Which of the following protocols allows the sender and receiver to enforce polices.

- ❖ RIP

- ❖ OSPF

- ❖ **BGP** (page 137)

- ❖ RIP and OSPF

228. ICMP message transport is acted upon by getting ICMP encrypted in IP.

- ❖ True

- ❖ **False**

229. These ICMP message transport is acted upon _____ as frames on _____

- ❖ Intranet, LAN

- ❖ Internet, WAN

- ❖ Intranet, WAN

- ❖ **Internet, LAN**

230. Address mask defines how many bits of address are in suffix?

- ❖ True

- ❖ **False**

231. A computer attached to a given network can only communicate with other computers attached to the same network. Is this a problem with multiple networks?

- ❖ **True**

- ❖ False

232. Find the class of the address:

11110011 10011011 11111011 00001111

- ❖ A

- ❖ C

- ❖ **E** (page 87)

- ❖ B

233. Inside computer each address are stored as a -----bit value.

AL-JUNAID TECH INSTITUTE

- ❖ 48
- ❖ 64
- ❖ 16

❖ 32 (page 103)

234. In _____, the protocol address assigned to a computer is chosen carefully so that computer's hardware address can be computed from the protocol address using basic Boolean and arithmetic operations.

- ❖ Address
- ❖ Resolution
- ❖ Table Lookup

❖ Message (Page 9)

235. H.LEN shows the header length in units of ____ Bits:

❖ 34

❖ 32 Page 105

❖ 30

❖ None of the given

236. End to End delivery Service of IP datagram is _____

❖ Connection oriented

❖ Connectionless Page 120

❖ both a and b

❖ none of the given

237. In Cyclic Redundancy Checking, CRC is _____.

❖ Divisor

❖ Quotient

❖ Remainder page 20

❖ Dividend

238. The satellite or radio topology in which all computers are connected to each other via satellite or radio wave is a kind of

❖ Broadcast network page 5

❖ Point-to-Point network

239. The process of forwarding a packet is called _____.

❖ Routing page 58

❖ Processing

❖ Hierarchical Addressing

❖ Source Addressing

240. Which statement is correct about Network Interface Card (NIC)?

I. NIC contains sufficient hardware to process data independent of system CPU

II. NIC looks like any other I/O device to system CPU

III. NIC also receives interrupt on incoming data.

❖ I and II

❖ II and III

❖ I and III

❖ All of the given options (page 40)

AL-JUNAID TECH INSTITUTE

241. While transmitting data from source A to destination B, 4 bits are changed during the transmission then the error is a _____.
- ❖ **Burst error** (page 22)
 - ❖ Single error
 - ❖ Double error
 - ❖ Logic error
242. The switch that has no attached computers is called _____.
- ❖ Packet Switch
 - ❖ Exterior Switch
 - ❖ **Interior Switch** (page 59)
 - ❖ External Switch
243. _____ is the most popular wiring scheme because of lowest cost.
- ❖ 5 Base T
 - ❖ **10 Base T** (page 43)
 - ❖ 100 base T
 - ❖ 1000 base T
244. In _____ technique, all members of the network can send data only on the specific time slot?
- ❖ CDMA
 - ❖ FDMA
 - ❖ **CSMA** (page 43)
 - ❖ TDMA
245. If a sender with a 100 Megabit NIC and receiver with 10 Megabit NIC wants to communicate with each other at which speed they can communicate?
- ❖ **100 Megabit** (page 40)
 - ❖ 110 Megabit
 - ❖ 1000 Megabit
 - ❖ 10 Megabit
246. Missing _____ in a frame format indicates receiving computer missed beginning of the message.
- ❖ eot
 - ❖ **soh** (page 16)
 - ❖ sot
 - ❖ eoh
247. The _____ of errors is difficult than the _____ of errors.
248. Source Independence phenomenon allows fast and efficient _____.
- ❖ Source Addressing
 - ❖ Routing
 - ❖ **Packet Switching** page 58
 - ❖ Store and forward
249. In distributed route computation process each packet switch computes its routing table locally and sends messages to the _____.
- ❖ Router
 - ❖ Graph

AL-JUNAID TECH INSTITUTE

- ❖ Neighbors page 63
 - ❖ WAN
250. The ___ layer of the OSI model takes the data from the physical layer and perform error checking.
- ❖ Transport
 - ❖ Data link google
 - ❖ Application
 - ❖ Presentation
251. CBR stands for _____.
- ❖ Constant Byte Rate
 - ❖ Constant Bit Rate (page 71)
 - ❖ Connection break Recovery
 - ❖ Constant Borrow Rate
252. A network that uses _____ usually consist of a single long cable to which computer attach.
- ❖ Star Topology
 - ❖ Ring Topology
 - ❖ Bus Topology page 26
 - ❖ Bus and Ring Topology
253. If simultaneous transmission occurs, the frames interfere with each other and this phenomenon is called _____.
- ❖ packet loss
 - ❖ collision page 28
 - ❖ delayed transmission
 - ❖ coordination
254. In _____ all computers are attached to a central hub
- ❖ Ring topology
 - ❖ Star topology page 31
 - ❖ Hub topology
 - ❖ Bus topology
- 194) If you as a network administrator want to know the traffic flow of your data while communicating with a remote computer which of the following will be used to know about intermediate routers?
- ❖ Ip config
 - ❖ Ping page 11
 - ❖ Trace route
 - ❖ Arp
255. Basic LAN technologies such as Ethernet, Token Ring, and FDDI use a _____.
- ▶ Connectionless service paradigm (, page 112)
 - ▶ Connection-oriented service paradigm
 - ▶ Both Connectionless and Connection-oriented service paradigm
 - ▶ None of the given
256. _____ protocols of TCP/IP layering model specify how to ensure reliable transfer.
- ▶ Physical Layer

AL-JUNAID TECH INSTITUTE

- ▶ Network Interface Layer
- ▶ Internet Layer

▶ **Transport Layer** (Page 84)

257. An Internet Address (IP address) is a unique _____ binary number assigned to a host and used for all communication with host

▶ 48-bit

▶ **32-bit** (Page 85)

▶ 24-bit

▶ None of the given

258. The address _____ identifies the physical network to which the computer is attached, while the _____ identifies an individual computer on that network.

▶ **prefix , suffix** (Page 85)

▶ suffix , prefix

▶ suffix , suffix

▶ None of the given

259. _____ provides connectionless service.

▶ TCP

▶ **UDP** (Page 120)

▶ IP

▶ None of the given

260. UDP and TCP are both _____ layer protocols

▶ Physical

▶ Data link

▶ Network

▶ **Transport** (Page 101)

261. Connection-oriented service, Point-to-point, Complete reliability, Full-duplex communication, Stream interface, Reliable connection startup and Graceful connection shutdown are the services provided by _____

▶ IP

▶ None of the given

▶ **TCP** (Page 123)

▶ UDP

262. ICMP message transport is acted upon by getting ICMP encrypted in IP.

▶ **True** (Page 117)

▶ False

263. Protocol addresses are abstractions provided by _____.

▶ hardware

▶ **software** (Page 93)

▶ operating system

▶ internet

264. These packets serve same purpose on _____ as frames on _____

▶ Intranet, LAN

▶ Internet, WAN

▶ Intranet, WAN

AL-JUNAID TECH INSTITUTE

▶ Internet, LAN (Page 101)

265. In IPv6 the type of address used for collection of computers with same prefix. Are known as_____.

- ▶ Anycast
- ▶ Unicast
- ▶ Multicast

▶ Non of the given (Page 114)

266. Special types of addresses in IPv6 used for multiple destinations; possibly not at same site. Are known as_____.

- ▶ Unicast
- ▶ Anycast

▶ Multicast (Page 114)

▶ Non of the given

267. UDP offers application programs a Message-Oriented Interface, applications can depend on protocol to preserve data boundaries.

▶ True (Page 120)

▶ False

268. Reliability is the responsibility of the _____ layer

- ▶ Network
- ▶ Datalink

▶ Transport (Page 123)

▶ Application

269. TCP uses _____ mechanism to control the flow of data.

▶ door

▶ window (Page 126)

▶ acknowledgment

▶ retransmission

270. The time for acknowledgement to arrival of packet depends on.

▶ Distance to destination and Current traffic conditions (Page 125)

▶ Current traffic conditions

▶ Distance to destination

▶ none of these

271. FDDI can transmits data at a rate of -----

▶ 100 million bits per second (Page 31)

▶ 10 million bits per second

▶ 1000 million bits per second

▶ None of the given

272. Computer networks are often called ----- because they use packet technology.

▶ Ethernet

▶ Switch networks

▶ Packet networks (google)

▶ None of the given

273. _____ is ideal in a situation where the group is small and all members are attached to contiguous Local Area Networks.

AL-JUNAID TECH INSTITUTE

▶ Flood-and –Prune (Page 143)

- ▶ Configuration-and -Tunneling
- ▶ Core-Based Discovery
- ▶ None of the given

274. Router that decrements TTL to ___ sends ICMP time exceeded message, with router's address as source address

- ▶ 3
- ▶ 2
- ▶ 1

▶ 0 (Page 118)

275. Protocol addresses are abstractions provided by _____.

- ▶ hardware
- ▶ software (Page 93)
- ▶ operating system
- ▶ internet

276. Although message exchange can be used to bind addresses, sending a request for each binding is hopelessly inefficient.

▶ True (Page 99)

▶ False

277. ARP is almost always used to bind a ___-bit IP address to a ___-bit Ethernet address.

▶ 32, 48 (Page 98)

- ▶ 24, 32
- ▶ 32, 64
- ▶ 32, 128

278. In the 1970s large organizations began to acquire multiple networks. Each network in the organization formed island. Employees needed to choose a computer appropriate for each task. So they needed multiple screens, keyboards and computers.

▶ False

▶ True (Page 81)

279. Which of the following is a correct representation of the IPv6?

▶ 105.220.136.100.255.255.255.255.0.0.18.128.140.10.255.255 (Page 114)

- ▶ 105.220.136.100.255.255.255.256.0.0.18.128.140.10.255.255
- ▶ 105.220.136.100.255.255.255.255.0.0.18.128.140.10.255.255.256
- ▶ 105.220.136.100.255.255.255.255.0.0.18.128.140.10.255

280. A datagram cannot be larger than _____ of a network over which it is sent.

❖ MTU (page 107)

- ❖ Size
- ❖ IP header
- ❖ None of the given

281. Which of the following statement is true regarding ATM?

- ❖ It is a single technology for voice, video and data
- ❖ It has low jitter and high capacity.
- ❖ It uses fixed size, small cells, 48 octet's data

❖ All of the above (page 72)

AL-JUNAID TECH INSTITUTE

282. TCP uses __ format for all messages.

a. Single HO page 128

d. Double

e. Multiple

f. None of the given

283. The maximum segment size of TCP flow control is _____

a. 3000 octets

b. 2000 octets

c. 1000 octets HO page 126

e. None of the given

284. In TCP when a computer sends a segment, the and fields refer to incoming data.

a. ACKNOWLEDGE NUMBER, WINDOW book page 445

b. SEQUENCE NUMBER, WINDOW

c. ACKNOWLEDGE NUMBER, SEQUENCE NUMBER

d. None of the given

285. _ is used for single destination computer.

a. Multicast

b. Broadcast

c. Unicast HO page 114

d. None of the given

286. Postfix defines how much of address used to identify network.

a. True

b. False HO page 103

287. _____ Source is responsible for fragmentation. a. IPV4

b. IPV6 HO page 113

288. H.LEN shows the header length in units of _____ bits a. 34

b. 32 HO page 105

c. 30

d. None of the given

289. NAT stands for _____

a. Network Address Translation HO page 128

AL-JUNAID TECH INSTITUTE

- d. Network Address Transmission
- e. Network Address Test
- f. None of the given

290. _____ Serve Same purpose in Internet as frames on LAN

- a. Packets

b. Virtual Packets **HO page 101**

- f. Virtual Frames
- g. Both b and c

291. . The amount of buffer space available at any time is called the window.

a. True **HO page 126**

- b. False

292. . NEXT HEADER field in the base header defines type of header it appears at the end of fixed-size base header.

a. True **HO page 112**

- b. False

293. . _____ uses window mechanism to control the flow of data.

- a. IP
- b. UDP

c. TCP **HO page 126**

- d. None of the given

294. The Header format of IPv6 is entirely different.

a. True **HO page 111**

- b. False

295. UDP packet is encapsulated in _____ datagram.

a. IP **HO page 122**

- d. TCP
- e. TCP/IP
- f. None of the given

297. . Reliability is not the responsibility of the Transport layer.

- a. True

b. False **HO page 123**

298. . Twice NAT is another variant of NAT. it is used with site that runs server. In this process NAT box is connected to Domain Name.

- a. False

b. True **HO page 131**

AL-JUNAID TECH INSTITUTE

299. . A popular use of -----is TCP Splicing. It interconnects two independent TCP connections and performs segment rewriting.

a. NAT

b. NAPT HO page 131

e. Twice NAT

f. All of these

300. The goal of _____ is to avoid adding retransmissions to an already congested network.

a. Packet control

b. Congestion control HO page 128

e. Transmission control

d. None of the given

301. TCP stands for _____

a. Transport control protocol

b. Transmission control protocol HO page 123

g. Terminal control protocol

h. None of the given

302. IPV6 128 bits address includes network prefix and _____.

a. Host Suffix HO page 114

d. Host prefix

e. Source Prefix

f. None of the given

303. TCP achieves _____ by retransmission.

e. Efficiency

f. Accuracy

c. Reliability HO page 125

AL-JUNAID TECH INSTITUTE

d. None of the given

22. Class A mask is 255.0.0.0 which is used for _____

a. Unicasting

b. Multicasting

c. Subnetting HO page 103

d. All of the given

304. TCP is a _____
protocol.

a. Point-to-Point HO page 123

b. Multi-Point

c. Both a and b

d. None of the given



AL-JUNAID TECH INSTITUTE

305. . There are _____ possibilities to detect the destination using Trace-route.

- a. 1
- b. 2 HO Page 118**
- c. 3
- d. None of the given

306. . The UDP stands for _____.

- a. Universal Datagram Protocol
- b. User Datagram Protocol HO page 119**
- c. United Datagram Protocol
- d. None of the given

307. _____ is less complex and easy to understand.

- a. TCP
- b. UDP HO page 120**
- e. IP
- f. None of the given

308. In IPV6 the 128 bit addresses unwidely in dotted decimal; requires _____ numbers.

- a. 12
- b. 14
- c. 16 HO page 114**
- d. None of the given

309. . _____ layer provides reliable delivery of datagram.

- a. Network HO page 104**
- b. Transport
- c. Datalink
- d. None of the given

AL-JUNAID TECH INSTITUTE

310. _____ identifies the application program that sent the data.

a. Destination port

b. Source port **Book page 445**

c. Logical address

d. None of the given

311. . Preliminary version of IP was called _____.

a. IP – New Generation (IPng)

b. IP – Next Generation (IPng) **HO page 110**

c. IP – Net Generation (IPng)

d. None of the given

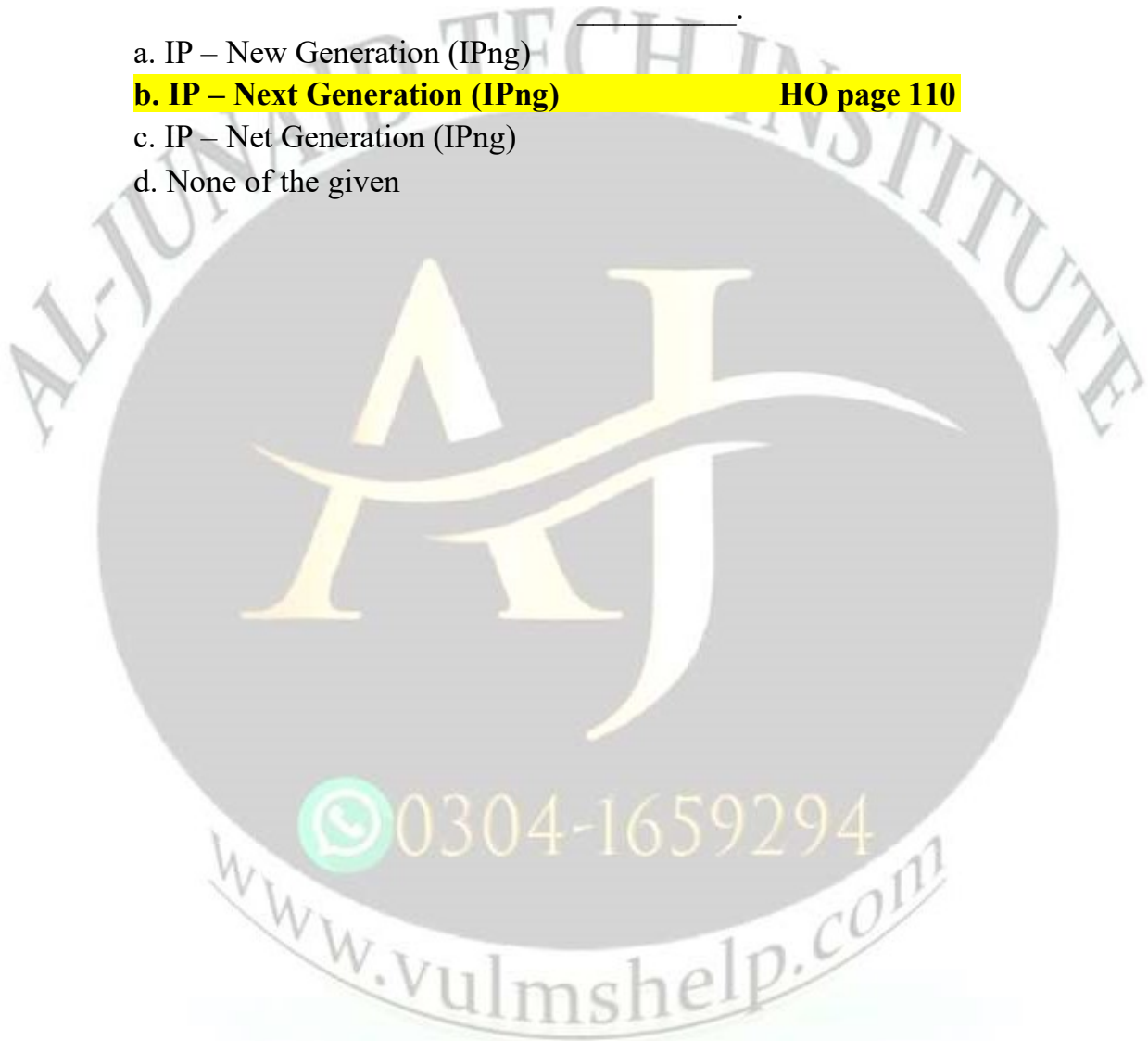

AL-JUNAID TECH INSTITUTE

312. TCP connections are not called Virtual connections.

a. True

b. False HO page 123

313. Header contains all information needed to deliver datagram to the destination computer. But which one of the following is not included:

a. Destination address

b. Source address

c. Rectifier HO page 102

d. Other delivery information

304.. TCP uses the term segment to refer to a _____.

a. Packet

b. Message book page 444 HO page 128

c. Both (a) and (b)

d. None of the given

305. Twice NAT fails if an application uses the IP addresses instead of Domain Name.

a. True HO page 132

b. False

306. _____ sends ICMP echo messages with increasing TTL.

g. Ping

h. Trace route

c. Tracert HO page 118

d. None of the given

307.. IPv6 _____ is responsible for fragmentation. Routers simply drop datagram's larger than network

a. Destination

b. Intermediate routers

c. Source HO page 113

d. Medium

308. . The Current version of IP-Version 4 is _____ old

AL-JUNAID TECH INSTITUTE

- a. 18 years
- b. 20 years** **HO page 110**

- c. 22 years
- d. none of given

309. . The process of learning the path MTU is known as path MTU discovery.

▶ True

▶ False

310. . UDP follows four types of interactions.

a. True **HO page 121**

b. False

311.. Routers use _____ to forward datagrams along prearranged path.

a. Traffic class

b. Flow label **HO page 111**

c. Destination address

d. none of the given

312. . For _____, information about forwarding is stored in a routing table,

which is initialized at system initialization and must be updated as network topology changes.

a. Efficiency **HO page 102**

b. Security

c. Accuracy

d. Anomalies

313. . TCP provides reliable connection startup.

a. True

b. False **HO page 123**

AL-JUNAID TECH INSTITUTE

314. . -----encapsulates IP datagram as data area in hardware frame.

a. Network Interface Layer

HO page 106

b. Datalink Layer

c. Network Layer

d. None of the given

315.. NAT software does not allow a PC to connect with the Internet and act as a NAT device at the same time.

a. True

b. False

HO page 132

316. _----- protocol uses three way handshake to begin a connection.

a. UDP

b. TCP

HO page 127

c. IP

d. none of the given

317. MTU Stands for _____

a. Minimum transmission unit

b. Maximum transmission unit

HO page 107

c. Multicast transmission unit

d. None of the given



0304-1659294

www.vulmshelp.com

AL-JUNAID TECH INSTITUTE

318. . Fragmentation when using ICMP for path MTU should be avoided.

a. True **HO page 118**

b. False

319. . System rebooting is one of the major problems in the reliable delivery

a. True **HO page 124**

b. False

320. Twice NAT requires the DNS to interact with the NAT device.

a. True **HO page 132**

b. False

321. The Universal Datagram Protocol is a message-oriented protocol.

a. True **Wikipedia**

b. False

322. Twice NAT allows a site to run servers.

a. True **HO page 132**

b. False

323.. TCP provides _____ communication.

a. Half-duplex

b. Full-duplex **HO page 53**

c. Both (a) and (b)

d. None of the given

324.. Routing refers to the _____ of routing information.

a. transmission

b. propagation **HO page 133**

c. communication

d. None of the given

325.. Basic NAT does not work well to communication initiated from the internet.

a. True **HO page 132**

b. False

326.. NAT device stores state information in translation table.

AL-JUNAID TECH INSTITUTE

a. True HO page 130

b. False

327.. HEADER LEN field gives size of extension header.

a. False

b. True HO page 112

328.. UDP provides connection-oriented service.

a. True

b. False HO Page 120

329. TTL stands for _____

a. Time to learn

b. Time to leave

c. Time to live HO page 105

d. None of the given

330. . In TCP/IP,----- provides reliable transport service.

a. IP

b. TCP HO page 123

c. Both IP and TCP

d. None of the given

331.. The Universal Datagram Protocol is not an end-to-end protocol.

a. True

b. False HO page 120 (User Datagram protocol is end to end)

332. . _____ Protocol provides error reporting mechanism.

a. IGMP

b. SNMP

c. ICMP HO page 115

d. none of the given

333.. Network Address Translation (NAT) requires device to perform packet translation.

AL-JUNAID TECH INSTITUTE

a. True **HO Page 128**

b. False

334. UDP datagram format is -----bits.

a. 8

b. 16

c. 32 **HO page 122**

d. 64

335.. Which one is NOT the function of ping program

a. Traceability **HO page 117**

b. Reachability

c. Both a and b

d. None of the given

336.. NAPT stands for _____.

a. Network Address and Protocol Translation

b. Network Address and Port Translation **HO page 131**

c. Network Address and Packet Translation

d. None of the given

337.. UDP uses best-effort delivery service.

a. True **HO page 120**

b. False

338.. ICMP message transport is acted upon by getting ICMP _____ in IP

a. De-encapsulated

b. Encapsulated **HO page 117**

c. Segmented

d. none of the given

339. . _____ identifies which application program on receiving computer should receive the data.

a. Logical address

b. Source port

c. Destination Port **Book page 445**

AL-JUNAID TECH INSTITUTE

- d. None of the given
340. . The Network Layer Protocol ICMP stands for _____
- a. Instant Control Message Protocol
 - b. Internet Control Message Protocol** **HO page 115**
 - c. Initial Control Message Protocol
 - d. None of the given
341. _____ field tells the receiver how to order fragments within a given datagram.
- a. FLAGS
 - b. FRAGMENT OFFSET** **Book page 375**
 - c. IDENTIFICATION
 - d. None of the given
- 342.. _____ contains all information needed to deliver datagram to the destination.
- a. Header** **HO page 102**
 - b. Data Area
 - c. Identifier
 - d. none of the given
343. NAT is not useful at a residence with Cable Modem or DSL connectivity. a. True
- b. False** **HO page 132**
344. TCP is a connectionless and reliable transport protocol.
- a. True
 - b. False** **HO page 123**
345. which is not the type of error messages defined by ICMP.
- a. Source quench
 - b. Time exceeded
 - c. Destination unreachable

AL-JUNAID TECH INSTITUTE

d. none of the given **HO page 115**

346. . Network Address and Port Translation (NAPT) is by far the most popular form of _____

a. Network Address Transmission

b. Network Address Translation **HO page 131**

c. Network Address Transformation

d. None of the given

347. . Network having short intervals has a large timeout and the network having large interval has short timeout.

a. True

b. False **HO page 126**

348. . One of the parameters, which motivated IP for change is address space. The _____ address space allows for over a million networks. But most networks are class C and too small for many organizations.

a. 32-bit **HO page 110**

b. 128-bit

c. 16-bit

d. 64-bit

349. . Every hardware technology specification includes the definition of the maximum size of the frame data area, which is called the _____ Transmission Unit.

a. Least

b. Maximum **HO page 107**

c. Fragment

d. Frame

350. . ----- provides computer to computer communication.

a. IP **HO page 119**

b. TCP

AL-JUNAID TECH INSTITUTE

c. ICMP

d. IGMP

351. . Address mask defines how many bits of address are in prefix.

▶ True

▶ False

352. . _____ shows senders preference for low latency, high Reliability.

a. TYPE

b. SERVICE TYPE HO page 105

c. SERVICE PRIORITY

d. None of the given

354. . IP datagram can contains _____ octets.

a. 0-65.535

b. 1-65.535 HO page 102

c. 1-65.536

d. none of the given

355. IPV6 address consists of _____

a. 32 Bits

b. 64 Bits

c. 128 Bits HO page 111

d. none of the given

356. . End to End delivery Service of IP datagram is _____

a. Connection oriented

b. Connectionless HO page 101

c. Both a and b

d. none of the given

AL-JUNAID TECH INSTITUTE

357.. The Source can configure outgoing datagram's to avoid _____

- a. Segmentation
- b. Defragmentation

c. Fragmentation **HO page 118**

- d. None of the given

358. . _____ is a technique used to Limit datagram size to small MTU of any network

- a. Segmentation

b. Fragmentation **HO page 108**

- c. Encapsulation
- d. None of the given

359. . _____ Message is sent in response to incoming datagrams with problems.

- a. TCP/IP
- b. IGMP

c. ICMP **HO page 117**

- d. none of the given

 0304-1659294
www.vulmshelp.com

AL-JUNAID TECH INSTITUTE

360. . Which protocol is used to test different tools.

a. ICMP **HO page 117**

b. IGMP

c. TCP/IP

d. none of the given

361. . Due to revolutionalization of IP-V6 the speed has increased from _____

a. 56kbps to 512kbps

b. 512kbps to 1gbps

c. 56kbps to 1gbps **HO page 110**

d. none of the given

362.. _____ field of header indicates whether a datagram is a fragment or a complete datagram.

a. FLAGS **Book page 373**

b. FRAGMENT OFFSET

c. IDENTIFICATION

d. None of the given

363. . In 3-way handshake TCP requires to generate a random _____ sequence number.

a. 30 bit

b. 32 bit **HO page 127**

c. 34 bit

d. none of the given

AL-JUNAID TECH INSTITUTE

364. . IPV6 addresses are _____ bits.

- a. 32
- b. 64
- c. 128**
- d. 256

HO page 111

365. . The time for acknowledgement to arrive depends on _____

- a. Distance to destination
- b. Current traffic conditions

c. Both a and b **HO page 125**

- d. none of the given

366. _____ is a type of address used for collection of computers with same prefix.

- a. Cluster**
- b. unicast

HO page 114

- c. Multicast
- d. none of the given

369. _____ field is used to identify a specific path through the network

a. FLOW LABEL **HO page 111**

- b. TRAFFIC CLASS
- c. Both a and b
- d. none of the given

370. . TCP is not connection-oriented service.

- a. True

b. False **HO page 123**

371.. IPV6 address with _____ leading zeros is interpreted to hold an IPV4

AL-JUNAID TECH INSTITUTE

address.

a. 96 **HO page 114**

b. 100

c. 120

d. none of the given

372. A datagram cannot be larger than _____ of a network over which it is sent.

a. MTU **HO page 113**

b. Size

c. IP header

d. None of the given

373. A _____ Relies on the hardware manufacturer to assign a unique physical address to each network interface.

▶ **Static addressing scheme (Page 34)**

- ▶ Configurable addressing scheme
- ▶ Dynamic addressing scheme
- ▶ None of the given

374. An interface for thin Ethernet must have an _____ connector, and must generate signals according to the _____ specification.

- ▶ RJ-45, 10 Base T
- ▶ RJ-45, 10 Base 5

▶ **BNC, 10 Base 2 (CS610 Reference Book , Page 21)**

- ▶ BNC, 10 Base T

374. A system with redundant bridges might have a problem with _____ in the system.

▶ **Loop**

- ▶ Filters
- ▶ Spanning Trees
- ▶ All given choices

375. A Bridge can _____

- ▶ Filter a frame

AL-JUNAID TECH INSTITUTE

▶ Forward a frame

▶ a LAN Do all the [Click here for detail](#)



AL-JUNAID TECH INSTITUTE

376. _____ is used for typical data applications (where the data rate may be unknown and bursty) and allows use of whatever bandwidth is available at a given time.

- ▶ Constant Bit Rate (CBR) service
- ▶ Variable Bit Rate (VBR) service
- ▶ **Available Bit Rate (ABR) service (Page 71)**
- ▶ None of the given

377. ATM assigns each VC a _____ identifier that is divided two parts to produce a hierarchy.

- ▶ 21-bit
- ▶ 22-bit
- ▶ 23-bit
- ▶ **24-bit (Page 67)**

378. _____ of TCP/IP layering model, corresponds to basic network hardware.

- ▶ **Physical Layer (Page 84)**
- ▶ Network Interface Layer
- ▶ Internet Layer
- ▶ Transport Layer

379.

_____ places the boundary between the second and third octets

- ▶ Class A
- ▶ **Class B (Computer Networks and Internets, page235)**
- ▶ Class C
- ▶ Class D

380. UDP and TCP are both _____ layer protocols

- ▶ Physical
- ▶ Data link
- ▶ Network
- ▶ **Transport (Page 101)**

381. Connection-oriented service, Point-to-point, Complete reliability, Full-duplex communication, Stream interface, Reliable connection startup and Graceful connection shutdown are the services provided

AL-JUNAID TECH INSTITUTE

- ▶ None of the given
- ▶ IP
- ▶ **TCP (Page 123)**
- ▶ UDP

382. _____ protocols of TCP/IP layering model specify how to ensure reliable transfer.

- ▶ Physical Layer
- ▶ Network Interface Layer
- ▶ Internet Layer
- ▶ **Transport Layer (Page 84)**

383.

_____ identifies which application program on receiving computer should receive the data

- ▶ Logical address
- ▶ Source port
- ▶ **Destination Port (Computer Networks and Internets, page313)**
- ▶ None of the given

384.

_____ identifies the application program that sent the data.

- ▶ Destination Port
- ▶ **Source port (Computer Networks and Internets, page313)**
- ▶ Logical address
- ▶ None of the given

385. Which of the following are interior routing protocols?

- ▶ RIP
- ▶ OSPF
- ▶ BGP
- ▶ **RIP and OSPF**

386. The Border Gateway Protocol (BGP) uses _____ for all communication

- ▶ UDP
- ▶ **TCP** !
- ▶ Both UDP and TCP

AL-JUNAID TECH INSTITUTE

- ▶ All of given

387.

_____ measures distance in network hops, where each network between the source and destination counts as a single hop.

- ▶ BGP
- ▶ OSPF
- ▶ **RIP (Page 138)**
- ▶ None of the given

388. OSPF is based on _____

- ▶ Distance vector routing
- ▶ **Link state routing (Page 140)**
- ▶ Path vector routing
- ▶ Distance vector routing and Link state routing

389.

_____ performs local multicast and uses IP-in-IP encapsulation to send multicast datagrams from one site on the Internet to another.

- ▶ **Distance Vector Multicast Routing Protocol (DVMRP) (Page 144)**

- ▶ Core Based Trees (CBT)
- ▶ Protocol Independent Multicast _ Sparse Mode (PIM-SM)
- ▶ Protocol Independent Multicast _ Dense Mode (PIM-DM)

390. The length of time required to send a variable length packet is variable and does not require a complicated interrupt scheme to detect completion of transmission.

- ▶ True
- ▶ **False (Page 72)**

391. NEXT HEADER field in the base header defines type of header and it appears at end of fixed-size base header.

- ▶ **True (Page 112)**
- ▶ False

392. Although message exchange can be used to bind addresses, sending a request for each binding is hopelessly inefficient.

- ▶ **True (Page 99)**

- ▶ False

393. A computer attached to a given network can only communicate with other computers attached to the same network. Is this a problem with multiple networks?

AL-JUNAID TECH INSTITUTE

▶ True (Page 81)

▶ False

394. In the 1970s large organizations began to acquire multiple networks. Each network in the organization formed island. Employees needed to choose a computer appropriate for each task. So they needed multiple screens, keyboards and computers.

▶ False

▶ True (Page 81)

395. The term self-identifying is used for Classful IP addresses because the class of the address can be computed from the address_____.

▶ itself (Page 87)

▶ prefix

▶ suffix

▶ mask

396. In which method of Address Resolution Protocol the protocol address independent of hardware address? Were "T" stands for Table lookup, "C" for Closed-form Computation and "D" for Data Exchange?

▶ T, C

▶ D

▶ C

▶ T, D (Page 97)

397. In which method of Address Resolution Protocol the protocol address is determined by hardware address? Were "T" stands for Table lookup, "C" for Closed-form Computation and "D" for Data Exchange?

▶ T

▶ D

▶ C (Page 97)

▶ T, C

398. Reconstruction of original datagram is called reassembly.

▶ True (Page 28)

▶ False

398. A computer needs a complete stack of protocols to run either a client or a server.

▶ True (Computer Networks and Internets, page 344)

▶ False

399. TCP uses__mechanism to control the flow of data.

AL-JUNAID TECH INSTITUTE

▶ door

▶ window (Page 126)

▶ acknowledgment

▶ retransmission



AL-JUNAID TECH INSTITUTE

400. In Direct point to point communication adding the Nth computer requires----- new connections.

None of the given
2

N

N-1 (Page 23)

$(N^2 - N)/2$

401. In -----, network occupies the smaller area like a room a floor or a building

LAN (Page 4)

WAN

MAN

None of the given



AL-JUNAID TECH INSTITUTE

402. The third field of the header consists of----- bit Ethernet frame type.

- 48
- 32
- 16
- 8

403. The maximum size of an Ethernet segment is _____

- 250 meters
- 500 meters
- 700 meters
- None of the given

404. The network with Throughput T and Delay D has a total----- bits in transit at a time.

- D + T
- D - T
- D X T (Computer Networks and Internets, page203)
- D / T

405.

_____ places the boundary between the first and second octets

- Class A (Computer Networks and Internets, page235)
- Class B
- Class C
- Class D

407. Router detects datagram ----- than network MTU and then it splits into pieces and each piece is ----- than outbound network MTU.

- Larger, smaller (Page 108)
- Larger, larger
- Smaller, larger
- Smaller, smaller

408. Connectionless service, Message-Oriented protocol, best-effort delivery service, arbitrary interaction & operating system independent are the characteristics of _____

AL-JUNAID TECH INSTITUTE

▶ **UDP (Page 120)**

- IP
- TCP
- None of the given

409. ----- provide Application to application communication it also called end to end communication

- IP

▶ **TP (Page 119)**

- RIP
- None of the given

410. A routing table contains _____

- The destination network ID
- The hop count to reach the network
- ▶ **The router ID of the next hop (Page 102)**
- All of the given

411. Which of the following protocols allows the sender and receiver to enforce policies.

- RIP
- OSPF
- ▶ **BGP (Reference Book 347)**
- RIP and OSPF

412. _____ measures distance in network hops, where each network between the source and destination counts as single hop.

- BGP
- OSPF
- ▶ **RIP (Page 138)**
- Non of these

413. ____ includes a 32-bits address mask with each address, which allows the address to be classful, classless, or subnetted.

- RIP
- ▶ **OSPF (Page 140)**
- BGP
- None of the given

AL-JUNAID TECH INSTITUTE

414. One repeater -----, two repeaters ----- the maximum cable length limitation.

▶ **Double, triple** (Page 49)

Double, 4 time

half, triple

Double, half

415. ICMP message transport is acted upon by getting ICMP encrypted in IP.

* **True** (Page 117)

False

416. Like most application programs, a client and server use a transport protocol to communicate.

▶ **True** (Page 146)

False

417. Mapping between a protocol address and a hardware address is called Address Resolution.

▶ **True** (Page 93)

False

418. Address mask defines how many bits of address are in suffix?

True

▶ **False** (Page 103)

419. A single networking technology is best for all needs.

True

▶ **False** (Page 81)

420. In the 1970s large organizations began to acquire multiple networks. Each network in the organization formed island. Employees needed to choose a computer appropriate for each task. So they needed multiple screens, keyboards and computers.

▶ False

▶ **True** (Page 81) rep

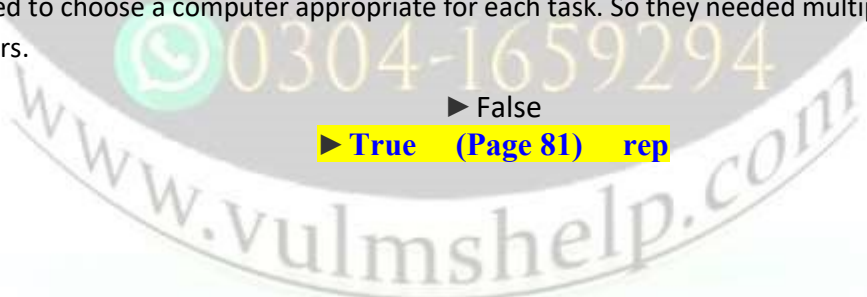

AL-JUNAID TECH INSTITUTE

421. Router detects datagram ---- than network MTU

▶ **Larger (Page 108) rep**

- ▶ Smaller
- ▶ None of given
- ▶ Equal

422. Information can flow in either or both direction between

- ▶ Clients
- ▶ **Clients and servers (Computer Networks and Internets, page 344)**
- ▶ Servers
- ▶ None of given

423. On of the design goals for unicast route propagation is_____.

- ▶ consistency
- ▶ inconsistency
- ▶ **stability (Computer Networks and Internets, page 344)**
- ▶ dynamic addressing

424. IPV6 address consists of _____

- ▶ 32 Bits
- ▶ 64 Bits
- ▶ **128 Bits (Page 128)**
- ▶ none of the given

424. UDP offers application programs a Message-Oriented Interface, applications can depend on protocol to preserve data boundaries.

▶ **True (Page 120)**

▶ False

425. In case TCP, retransmission, acknowledgment from a computer on LAN are expected to arrive within

- ☐ Seconds
- ☐ Micro seconds
- ☐ **Milliseconds** [Click here for detail](#)
- ☐ Nanoseconds

AL-JUNAID TECH INSTITUTE

426. Twice NAT is another variant of NAT. it is used with site that runs server. In this process NAT box is connected to Domain Name.

- ▶ **True (Page 131)**
- ▶ False

427. A network uses a --arranges for computers to be connected in a closed loop.

- ▶ Star Topology
- ▶ **Ring Topology (Page 25)**
- ▶ Bus Topology
- ▶ None of the given

428. Protocol addresses are abstractions provided by_____.

- ▶ hardware
- ▶ **software (Page 93)**
- ▶ operating system
- ▶ internet

429. In Direct point to point communication adding the Nth computer requires----- new connections.

- ▶ None of the given
- ▶ N^2
- ▶ **$N-1$ (Page 23)**
- ▶ $(N^2 - N)/2$



AL-JUNAID TECH INSTITUTE

430. In Point-to-Point topology there are two topologies.

- ▶ Tree and Ring
- ▶ Star and Ring
- ▶ **Star and Tree (Page 5)**
- ▶ None of the given

431. In-----, network occupies the smaller area like a room a floor or a building

▶ **LAN (Page 4)**

- ▶ WAN
- ▶ MAN
- ▶ None of the given

432. Hardware that calculates a CRC uses two simple components.

- ▶ AND unit and XOR unit
- ▶ **Shift register and XOR unit (Page 20)**
- ▶ Shift register and AND unit
- ▶ None of the given

433. CRC can detect more errors than a simple checksum.

- ▶ **true (Computer Networks and Internets, page 80)**
- ▶ false

434. The Gigabit Ethernet hardware operates at a rate of -----

- ▶ 10 Mbps
- ▶ 100 Mbps
- ▶ **1000 Mbps Click here for detail**
- ▶ None of the given

435. Formally named _____ informally known as the twisted pair Ethernet or TP Ethernet.

- ▶ 10 Base 2
- ▶ 10 Base 5
- ▶ **10 Base T (Page 43)**
- ▶ None of the given



AL-JUNAID TECH INSTITUTE

436. An interface for thin Ethernet must have an _____ connector , and must generate signals according to the _____ specification.

- ▶ RJ-45, 10 Base T
- ▶ RJ-45, 10 Base 5
- ▶ **BNC, 10 Base 2 (cs610 reference book Page 201)**
- ▶ BNC, 10 Base T

437. A system with redundant bridges might have a problem with _____ in the system.

▶ **Loop** rep

- ▶ Filters
- ▶ Spanning Trees
- ▶ All given choices

438. _____ computes shortest paths in a graph by using weights on edges as a measure of distance.

- ▶ Greedy algorithm
- ▶ Distance vector algorithm
- ▶ **Dijkstra's algorithm (Computer Networks and Internets, page 112)**
- ▶ Non of the given

439. Basic LAN technologies such as Ethernet, Token Ring, and FDDI use a _____.

▶ **Connectionless service paradigm (Computer Networks and Internets, page 112)**

- ▶ Connection-oriented service paradigm
- ▶ Both Connectionless and Connection-oriented service paradigm
- ▶ None of the given

440. _____ protocols of TCP/IP layering model specify how to ensure reliable transfer.

- ▶ Physical Layer
- ▶ Network Interface Layer
- ▶ Internet Layer
- ▶ **Transport Layer (Page 84) rep**

AL-JUNAID TECH INSTITUTE

441. An Internet Address (IP address) is a unique _____ binary number assigned to a host and used for all communication with host

- ▶ 48-bit
- ▶ **32-bit (Page 85)**
- ▶ 24-bit
- ▶ None of the given

442. _____ places the boundary between the first and second octets

▶ **Class A (Computer Networks and Internets, page 235)**

- ▶ Class B
- ▶ Class C
- ▶ Class D

443. _____ places the boundary between the third and fourth octets.

- ▶ Class A
- ▶ Class B

▶ **Class C (Computer Networks and Internets, page 235)**

- ▶ Class D

444. _____ field of header indicates whether a datagram is a fragment or a complete datagram.

▶ **FLAGS Click here for detail**

- ▶ FLAGMENT OFFSET
- ▶ IDENTIFICATION
- ▶ None of the given



AL-JUNAID TECH INSTITUTE

445. ___ provides connectionless service.

- ▶ TCP
- ▶ **UDP (Page 120)**
- ▶ IP
- ▶ None of the given

446. UDP and TCP are both ___ layer protocols

- ▶ Physical
- ▶ Data link
- ▶ Network
- ▶ **Transport (Page 101) rep**

447. Connection-oriented service, Point-to-point, Complete reliability, Full-duplex communication, Stream interface, Reliable connection startup and Graceful connection shutdown are the services provided by ___

- ▶ IP
- ▶ None of the given
- ▶ **TCP (Page 123) rep**
- ▶ UDP

448. ___ protocols of TCP/IP layering model specify how to ensure reliable transfer.

- ▶ Physical Layer
- ▶ Network Interface Layer
- ▶ Internet Layer

▶ **Transport Layer (Page 84) rep**

449. ___ identifies which application program on receiving computer should receive the data

- ▶ Logical address
- ▶ Source port
- ▶ **Destination Port (Computer Networks and Internets, page 313) rep**
- ▶ None of the given

AL-JUNAID TECH INSTITUTE

450.

_____ identifies the application program that sent the data.

- ▶ DestinationPort
- ▶ **Source port (Computer Networks and Internets, page313) rep**
- ▶ Logical address
- ▶ None of the given

451. The Border Gateway Protocol (BGP) uses _____ for all communication

- ▶ UDP
- ▶ **TCP rep**
- ▶ Both UDP and TCP
- ▶ None of the given

452. Which of the following protocols allows the sender and receiver to enforce policies.

- ▶ RIP
- ▶ OSPF
- ▶ **BGP (Reference Book 347) rep**
- ▶ RIP and OSPF

453. _____ uses distance vector approach to define routing

- ▶ BGP
- ▶ OSPF
- ▶ **RIP (Computer Networks and Internets, page332)**
- ▶ None of the given

454. ICMP message transport is acted upon by getting ICMP encrypted in IP.

- ▶ **True (Page 117)**
- ▶ False

AL-JUNAID TECH INSTITUTE

455. Protocol addresses are abstractions provided by_____.

- ▶ hardware
- ▶ **software (Page 93) rep**
- ▶ operating system
- ▶ internet

456. These packets serve same purpose on _____ as frames on _____

- ▶ Intranet, LAN
- ▶ Internet, WAN
- ▶ Intranet, WAN
- ▶ **Internet, LAN (Page 101)**

457. Address mask defines how many bits of address are in suffix?

- ▶ True
- ▶ **False (Page 103) rep**

458. A single networking technology is best for all needs.

- ▶ True
- ▶ **False (Page 81) rep**

459. A computer attached to a given network can only communicate with other computers attached to the same network. Is this a problem with multiple networks?

- ▶ **True (Page 81) rep**

- ▶ False

460.

The term self-identifying is used for Classful IP addresses because the class of the address can be computed from the address_____.

- ▶ **itself (Page 87)**

- ▶ prefix
- ▶ suffix
- ▶ mask



AL-JUNAID TECH INSTITUTE

461. Find the class of the address.

10100111 11011011 10001011 01101111

- ▶ A
- ▶ **B (Computer Networks and Internets, page 122)**
- ▶ D
- ▶ C

462. Find the class of the address:

11110011 10011011 11111011 00001111

- ▶ A
- ▶ **E (Computer Networks and Internets, page 122)**
- ▶ C
- ▶ B

463. In which method of Address Resolution Protocol the protocol address is determined by hardware address? Where "T" stands for Table lookup, "C" for Closed-form Computation and "D" for Data Exchange?

- ▶ T
- ▶ D
- ▶ **C (Page 97) rep**
- ▶ T, C

464. Which method of Address Resolution Protocol requires hardware broadcast?

Where "T" stands for Table lookup, "C" for Closed-form Computation and "D" for Data Exchange?

- ▶ **D (Page 97)**
- ▶ T
- ▶ C
- ▶ T, D

AL-JUNAID TECH INSTITUTE

465. Which method of Address Resolution Protocol resolution with minimum delay?

Were "T" stands for Table lookup, "C" for Closed-form Computation and "D" for Data Exchange?

- ▶ T, D
- ▶ c
- ▶ T

▶ **T, C (Page 97)**

466. In which method of Address Resolution Protocol the implementation is more difficult?

Were "T" stands for Table lookup, "C" for Closed-form Computation and "D" for Data Exchange?

- ▶ T, C
- ▶ T
- ▶ C

▶ **D (Page 97)**

467. One of the design goals for unicast route propagation is _____.

- ▶ Consistency
- ▶ inconsistency

▶ **stability (Computer Networks and Internets, page 344) rep**

- ▶ dynamic addressing

468. Propagation multicast routing information differs dramatically from unicast route propagation?

▶ **True (Computer Networks and Internets, page 335)**

- ▶ False

469. The IP multicast abstraction allows an application running on an arbitrary computer to leave a multicast group at any time. While _____ application on a computer remain a member of a group.

▶ **One or more**

- ▶ only one
- ▶ no
- ▶ many

AL-JUNAID TECH INSTITUTE

470. To save traffic, an EGP does not summarize routing information from the autonomous system before passing it to another autonomous system.

▶ True

▶ **False (Computer Networks and Internets, page 329)**

471. In IPv6 the type of address used for collection of computers with same prefix. Are known as _____.

▶ Anycast

▶ Unicast

▶ Multicast

▶ **Non of the given (Page 114)**

472. Special types of addresses in IPv6 used for multiple destinations; possibly not at same site. Are known as _____.

▶ Unicast

▶ Anycast

▶ **Multicast (Page 114)**

▶ Non of the given

473. UDP offers application programs a Message-Oriented Interface, applications can depend on protocol to preserve data boundaries.

▶ **True (Page 120) rep**

▶ False

474. Reliability is the responsibility of the _____ layer

▶ Network

▶ Datalink

▶ **Transport (Page 123)**

▶ Application

475. We use the term _____ to refer to a measure of the path that routing software use when choosing a route.

routing path

routing metric

routing (Computer Networks and Internets, page 330)

switching

AL-JUNAID TECH INSTITUTE

476. TCP uses ___ mechanism to control the flow of data.

477. door

▶ **window (Page 126) rep**

- ▶ acknowledgment
- ▶ retransmission

TCP uses window mechanism to control the flow of data.

478. The time for acknowledgement to arrival of packet depends on.

▶ **Distance to destination and Current traffic conditions (Page 125)**

- ▶ Current traffic conditions
- ▶ Distance to destination
- ▶ non of these

479. FDDI can transmits data at a rate of -----

▶ **100 million bits per second (Page 31)**

- ▶ 10 million bits per second
- ▶ 1000 million bits per second
- ▶ None of the given

480.

Computer networks are often called ----- because they use packet technology.

- ▶ Ethernet
- ▶ Switch networks
- ▶ **Packet networks (Computer Networks and Internets, page 73)**
- ▶ None of the given

481. A network uses a _____ arranges for computers to be connected in a closed loop.

- ▶ Star Topology
- ▶ **Ring Topology (Page 25) rep**
- ▶ Bus Topology

AL-JUNAID TECH INSTITUTE

- ▶ None of the given

482.

An----- method, the network hardware designers specify how type information is included in the frame and the value use to identify various frame types.

▶ **Explicit frame type (Computer Networks and Internets, page 108)**

- ▶ Ideal frame type
- ▶ Implicit frame type
- ▶ None of the given

483. An interface for thin Ethernet must have an _____ connector , and must generate signals according to the _____ specification.

- ▶ RJ-45, 10 Base T
- ▶ RJ-45, 10 Base 5

▶ **BNC, 10 Base 2 (cs610 reference book Page 201) rep**

- ▶ BNC, 10 Base T

484. A Bridge forwards or filters a frame by comparing the information in its address table to the frame's _____

- ▶ Layer 2 source address
- ▶ Source node's physical address

▶ **Layer 2 destination address Click here for detail**

- ▶ Layer 3 destination address

485. Most WAN systems include a mechanism that can be used to eliminate the common case of duplication routing is called _____

- ▶ Hierarchal address

▶ **Default route (Computer Networks and Internets, page 172)**

- ▶ Shortest path
- ▶ None of the given

486. ____ of TCP/IP layering model, corresponds to basic network hardware.

▶ **Physical Layer (Page 84) rep**

- ▶ Network Interface Layer
- ▶ Internet Layer
- ▶ Transport Layer

AL-JUNAID TECH INSTITUTE

487. _____ protocols of TCP/IP layering model specify how to ensure reliable transfer.

- ▶ Physical Layer
- ▶ Network Interface Layer
- ▶ Internet Layer
- ▶ **Transport Layer (Page 84) rep**

488. _____ is called an end-to-end protocol because it provides a connection directly from an application on one computer to an application on a remote computer.

- ▶ IP
- ▶ UDP

▶ **TCP (Computer Networks and Internets, page 306)**

- ▶ None of the given

489. _____ uses distance vector approach to define routing

- ▶ BGP
- ▶ OSPF

▶ **RIP (Computer Networks and Internets, page 332) rep**

- ▶ None of the given

490. _____ is ideal in a situation where the group is small and all members are attached to contiguous Local Area Networks.

▶ **Flood-and-Prune (Page 143)**

- ▶ Configuration-and-Tunneling
- ▶ Core-Based Discovery
- ▶ None of the given

491. Router that decrements TTL to _____ sends ICMP time exceeded message, with router's address as source address

- ▶ 3
- ▶ 2
- ▶ 1

▶ **0 (Page 118)**

AL-JUNAID TECH INSTITUTE

492. Protocol addresses are abstractions provided by _____.

- ▶ hardware
- ▶ **software (Page 93) rep**
- ▶ operating system
- ▶ internet

493. Although message exchange can be used to bind addresses, sending a request for each binding is hopelessly inefficient.

- ▶ **True (Page 99) rep**
- ▶ False

494. ARP is almost always used to bind a -bit IP address to a -bit Ethernet address.

- ▶ **32, 48 (Page 98)**
- ▶ 24, 32
- ▶ 32, 64
- ▶ 32, 128

495. In the 1970s large organizations began to acquire multiple networks. Each network in the organization formed island. Employees needed to choose a computer appropriate for each task. So they needed multiple screens, keyboards and computers.

- ▶ False
- ▶ **True (Page 81) rep**

496. In which method of Address Resolution Protocol the protocol address is determined by hardware address? Where "T" stands for Table lookup, "C" for Closed-form Computation and "D" for Data Exchange?

Features	Types of Resolution
Use full with any hardware	T
Address change affects all hosts	T
Protocol address is determined by hardware address	C

- ▶ T
- ▶ D
- ▶ **C (Page 97) rep**
- ▶ T, C

AL-JUNAID TECH INSTITUTE

497.. The general form of an IP datagram is with a header followed by data. The header contains information that controls where and how the datagram is to be sent.

▶ **True** (Computer Networks and Internets, page 332)

▶ False

498. To save traffic, an EGP does not summarize routing information from the autonomous system before passing it to another autonomous system.

▶ True

▶ **False** (Computer Networks and Internets, page 329)

499. Which of the following is a correct representation of the IPv6?

▶ **105.220.136.100.255.255.255.255.0.0.18.128.140.10.255.255** (Page 114)

▶ 105.220.136.100.255.255.255.256.0.0.18.128.140.10.255.255

▶ 105.220.136.100.255.255.255.255.0.0.18.128.140.10.255.255.256

▶ 105.220.136.100.255.255.255.255.0.0.18.128.140.10.255

500. The number of connections needed for N computer in direct point to point communication is equal to:

▶ **$(N^2 - N)/2$** (Page 23)

☐ $N(N-1)$

☐ N^2

☐ None of the given

501. When an application ----- data, it makes a copy of the data available to all other computers on the network.

☐ **Broadcasting**

☐ Multicasting

☐ Unicasting

☐ None of the given

502. In which method of Address Resolution Protocol the protocol address is determined by hardware address? Where "T" stands for Table lookup, "C" for Closed-form Computation and "D" for Data Exchange?

☐ T

☐ D

☐ **C** (Page 97) rep

☐ T, C

AL-JUNAID TECH INSTITUTE

503. Ethernet uses a _____ bit static addressing scheme in which each device is assigned a unique address by the manufacturer.

64

48 (Computer Networks and Internets, page 109)

32

8

504. A system with redundant bridges might have a problem with _____ in the system.

Loop [Click here for detail](#) rep

Filters

Spanning Trees

All given choices

505. The product of delay and throughput measures the _____ of data that can be present on the network.

Area

Volume (Page 80) rep

Length

None of the given

506. Connectionless service, Message-Oriented protocol, best effort delivery service, arbitrary interaction and operating system independent are the characteristics of _____

TCP

UDP (Page 110)

IP

None of the given

507. Connection-oriented service, Point-to-point, Complete reliability, Full-duplex communication, Stream interface, Reliable connection startup and Graceful connection shutdown are the services provided

by _____

None of the given

TCP (Page 123) rep

UDP

IP

AL-JUNAID TECH INSTITUTE

508. The process of using a routing table to select a next hop for a given datagram is called _____

Encapsulation

Reassembling

Routing or forwarding (Computer Networks and Internets, page 265)

None of the given

509. _____ uses distance vector approach to define routing

BGP

OSPF

RIP (Computer Networks and Internets, page 332) rep

None of the given

510. A multicast routing scheme in which the protocol software builds a delivery tree from a central point is called _____

Distance Vector Multicast Routing Protocol (DVMRP)

Core Based Trees (CBT) (Page 114)

Protocol Independent Multicast _ Sparse Mode (PIM-SM)

Protocol Independent Multicast _ Dense Mode (PIM-DM)

511. One repeater __, two repeaters _____ the maximum cable length limitation.

doubles, cancel

doubles, triple (Page 49) rep

square roots, cube roots

and, triple

512. Whenever it handles a packet, IP software needs to separate the destination address into a _____ and

postfix, Infix

non of these

Infix, prefix

prefix, suffix (Page 87)

AL-JUNAID TECH INSTITUTE

513.. Although message exchange can be used to bind addresses, sending a request for each binding is hopelessly inefficient.

▶ True (Page 99) rep

False

514. ARP is almost always used to bind a -bit IP address to a -bit Ethernet address.

▶ 32, 48 (Page 98)

24, 32

32, 64

32, 128

515. End-to-end delivery service is connection oriented.

True

▶ False (Page 101)

516. A single networking technology is best for all needs.

True

▶ False (Page 81) rep

517. In the 1970s large organizations began to acquire multiple networks. Each network in the organization formed an island. Employees needed to choose a computer appropriate for each task. So they needed multiple screens, keyboards and computers.

False

▶ True (Page 81)

518. Which method of Address Resolution Protocol is useful with any hardware?

Were "T" stands for Table lookup, "C" for Closed-form Computation and "D" for Data Exchange?

▶ T (Page 97)

C

D

C, D

AL-JUNAID TECH INSTITUTE



 0304-1659294

www.vulmshelp.com



CS610- Computer Network
Solved MCQS
From Final term Papers

June 23,2012

MC100401285

Moaaz.pk@gmail.com

Mc100401285@vu.edu.pk

PSMD01

CS610- Computer Network
FINAL TERM EXAMINATION - Spring 2010

Question No: 1(M a r k s: 1)

A ----- Relies on the hardware manufacturer to assign a unique physical address to each network interface.

- ▶ **Static addressing scheme (Page 34)**
- ▶ Configurable addressing scheme
- ▶ Dynamic addressing scheme
- ▶ None of the given

Question No: 2 (M a r k s: 1)

An interface for thin Ethernet must have an _____ connector, and must generate signals according to the _____ specification.

- ▶ RJ-45, 10 Base T
- ▶ RJ-45, 10 Base 5
- ▶ **BNC, 10 Base 2 (CS610 Reference Book , Page 21)**
- ▶ BNC, 10 Base T

Question No: 3(M a r k s: 1)

A system with redundant bridges might have a problem with _____ in the system.

- ▶ **Loop** [Click here for detail](#)
- ▶ Filters
- ▶ Spanning Trees
- ▶ All given choices

Question No: 4(M a r k s: 1)

A Bridge can _____

- ▶ Filter a frame
- ▶ Forward a frame
- ▶ Extend a LAN
- ▶ **Do all the** [Click here for detail](#)

Muhammad Moaaz Siddiq MCS (3rd)
mc100401285@gmail.com
Campus:- Institute of E-Learning & Modern Studies
(IEMS) Samundari

Question No: 5(M a r k s: 1)

_____ is used for typical data applications (where the data rate may be unknown and bursty) and allows use of whatever bandwidth is available at a given time.

- ▶ Constant Bit Rate (CBR) service
- ▶ Variable Bit Rate (VBR) service
- ▶ **Available Bit Rate (ABR) service (Page 71)**
- ▶ None of the given

Question No: 6(M a r k s: 1)

ATM assigns each VC a _____ identifier that is divided two parts to produce a hierarchy.

- ▶ 21-bit
- ▶ 22-bit
- ▶ 23-bit
- ▶ **24-bit (Page 67)**

Question No: 7(M a r k s: 1)

_____ of TCP/IP layering model, corresponds to basic network hardware.

- ▶ **Physical Layer (Page 84)**
- ▶ Network Interface Layer
- ▶ Internet Layer
- ▶ Transport Layer

Question No: 8(M a r k s: 1)

_____ places the boundary between the second and third octets

- ▶ Class A
- ▶ **Class B (Computer Networks and Internets, page235)**
- ▶ Class C
- ▶ Class D

Question No: 9(M a r k s: 1)

UDP and TCP are both_____ layer protocols

- ▶ Physical
- ▶ Data link
- ▶ Network
- ▶ **Transport (Page 101)**

Question No: 10(M a r k s: 1)

Connection-oriented service, Point-to-point, Complete reliability, Full-duplex communication, Stream interface, Reliable connection startup and Graceful connection shutdown are the services provided by_____

Muhammad Moaaz Siddiq MCS (3rd)

mc100401285@gmail.com

Campus:- Institute of E-Learning & Modern Studies
(IEMS) Samundari

- ▶ IP
- ▶ None of the given
- ▶ **TCP (Page 123)**
- ▶ UDP

Question No: 11(M a r k s : 1)

_____ protocols of TCP/IP layering model specify how to ensure reliable transfer.

- ▶ Physical Layer
- ▶ Network Interface Layer
- ▶ Internet Layer
- ▶ **Transport Layer (Page 84)**

Question No: 12(M a r k s : 1)

_____ identifies which application program on receiving computer should receive the data

- ▶ Logical address
- ▶ Source port
- ▶ **Destination Port (Computer Networks and Internets, page313)**
- ▶ None of the given

Question No: 13(M a r k s : 1)

_____ identifies the application program that sent the data.

- ▶ Destination Port
- ▶ **Source port (Computer Networks and Internets, page313)**
- ▶ Logical address
- ▶ None of the given

Question No: 14(M a r k s : 1)

Which of the following are interior routing protocols?

- ▶ RIP
- ▶ OSPF
- ▶ BGP
- ▶ **RIP and OSPF** [Click here for detail](#)

Question No: 15(M a r k s : 1)

The Border Gateway Protocol (BGP) uses _____ for all communication

- ▶ UDP
- ▶ **TCP** [Click here for detail](#)
- ▶ Both UDP and TCP
- ▶ None of the given

Question No: 16(M a r k s: 1)

_____measures distance in network hops, where each network between the source and destination counts as single hop.

- ▶ BGP
- ▶ OSPF
- ▶ **RIP (Page 138)**
- ▶ None of the given

Question No: 17(M a r k s: 1)

OSPF is based on_____

- ▶ Distance vector routing
- ▶ **Link state routing (Page 140)**
- ▶ Path vector routing
- ▶ Distance vector routing and Link state routing

Question No: 18(M a r k s: 1)

_____ performs local multicast and uses IP-in-IP encapsulation to send multicast datagrams from one site on the Internet to another.

- ▶ **Distance Vector Multicast Routing Protocol (DVMRP) (Page 144)**
- ▶ Core Based Trees (CBT)
- ▶ Protocol Independent Multicast_ Sparse Mode (PIM-SM)
- ▶ Protocol Independent Multicast _ Dense Mode (PIM-DM)

Question No: 19(M a r k s: 1)

The length of time required to send a variable length packet is variable and does not require a complicated interrupt scheme to detect completion of transmission.

- ▶ True
- ▶ **False (Page 72)**

Question No: 20(M a r k s: 1)

NEXT HEADER field in the base header defines type of header and it appears at end of fixed-size base header.

- ▶ **True (Page 112)**
- ▶ False

Question No: 21(M a r k s: 1)

Although message exchange can be used to bind addresses, sending a request for each binding is hopelessly inefficient.

- ▶ **True (Page 99)**
- ▶ False

Muhammad Moaaz Siddiq MCS (3rd)

mc100401285@gmail.com

Campus:- Institute of E-Learning & Modern Studies
(IEMS) Samundari

Question No: 22(M a r k s: 1)

Address mask defines how many bits of address are in suffix.

- ▶ True
- ▶ **False (Page 103)**

Question No: 23(M a r k s: 1)

A computer attached to a given network can only communicate with other computers attached to the same network. Is this a problem with multiple networks?

- ▶ **True (Page 81)**
- ▶ False

Question No: 24(M a r k s: 1)

In the 1970s large organizations began to acquire multiple networks. Each network in the organization formed island. Employees needed to choose a computer appropriate for each task. So they needed multiple screens, keyboards and computers.

- ▶ False
- ▶ **True (Page 81)**

Question No: 25(M a r k s: 1)

The term self-identifying is used for Classful IP addresses because the class of the address can be computed from the address_____.

- ▶ **itself (Page 87)**
- ▶ prefix
- ▶ suffix
- ▶ mask

Question No: 26(M a r k s: 1)

In which method of Address Resolution Protocol the protocol address independent of hardware address? Were "T" stands for Table lookup, "C" for Closed-form Computation and "D" for Data Exchange?

- ▶ T, C
- ▶ D
- ▶ C
- ▶ **T, D (Page 97)**

Question No: 27(M a r k s: 1)

In which method of Address Resolution Protocol the protocol address is determined by hardware address? Were "T" stands for Table lookup, "C" for Closed-form Computation and "D" for Data Exchange?

- ▶ T
- ▶ D
- ▶ **C (Page 97)**
- ▶ T, C

Muhammad Moaaz Siddiq MCS (3rd)

mc100401285@Gmail.com

Campus:- Institute of E-Learning & Modern Studies
(IEMS) Samundari

Question No: 28(M a r k s: 1)

Reconstruction of original datagram is called reassembly.

▶ **True (Page 28)**

▶ False

Question No: 29(M a r k s: 1)

A computer needs a complete stack of protocols to run either a client or a server.

▶ **True (Computer Networks and Internets, page 344)**

▶ False

Question No: 30(M a r k s: 1)

TCP uses _____ mechanism to control the flow of data.

▶ door

▶ **window (Page 126)**

▶ acknowledgment

▶ retransmission

FINAL TERM EXAMINATION
Spring 2010
CS610- Data Communication

Question No: 1 (Marks: 1) - Please choose one

In Direct point to point communication adding the Nth computer requires----- new connections.

▶ None of the given

▶ N^2

▶ **N-1 (Page 23)**

▶ $(N^2 - N)/2$

Question No: 2 (Marks: 1) - Please choose one

In -----, network occupies the smaller area like a room a floor or a building

▶ **LAN (Page 4)**

▶ WAN

▶ MAN

▶ None of the given

Muhammad Moaaz Siddiq MCS (3rd)

mc100401285@gmail.com

Campus:- Institute of E-Learning & Modern Studies
(IEMS) Samundari

Question No: 3 (Marks: 1) - Please choose one

The third field of the header consists of ----- bit Ethernet frame type.

- ▶ 48
- ▶ 32
- ▶ **16** [Click here for detail](#)
- ▶ 8

Question No: 4 (Marks: 1) - Please choose one

The maximum size of an Ethernet segment is _____

- ▶ 250 meters
- ▶ **500 meters** [Click here for detail](#)
- ▶ 700 meters
- ▶ None of the given

Question No: 5 (Marks: 1) - Please choose one

The network with Throughput T and Delay D has a total ----- bits in transit at a time.

- ▶ D + T
- ▶ D – T
- ▶ **D X T** ([Computer Networks and Internets, page203](#))
- ▶ D / T

Question No: 6 (Marks: 1) - Please choose one

_____ places the boundary between the first and second octets

- ▶ **Class A** ([Computer Networks and Internets, page235](#))
- ▶ Class B
- ▶ Class C
- ▶ Class D

Question No: 7 (Marks: 1) - Please choose one

Router detects datagram ----- than network MTU and then it splits into pieces and each piece is -----than outbound network MTU.

- ▶ **Larger, smaller** ([Page 108](#))
- ▶ Larger, larger
- ▶ Smaller, larger
- ▶ Smaller, smaller

Question No: 9 (Marks: 1) - Please choose one

Connectionless service, Message-Oriented protocol, best-effort delivery service, arbitrary interaction & operating system independent are the characteristics of _____

- ▶ TCP
- ▶ **UDP (Page 120)**
- ▶ IP
- ▶ None of the given

Question No: 10 (Marks: 1) - Please choose one

----- provide Application to application communication it also called end to end communication

- ▶ IP
- ▶ **TP (Page 119)**
- ▶ RIP
- ▶ None of the given

Question No: 11 (Marks: 1) - Please choose one

A routing table contains_____

- ▶ The destination network ID
- ▶ The hop count to reach the network
- ▶ **The router ID of the next hop (Page 102)**
- ▶ All of the given

Question No: 12 (Marks: 1) - Please choose one

Which of the following protocols allows the sender and receiver to enforce policies.

- ▶ RIP
- ▶ OSPF
- ▶ **BGP (Reference Book 347)**
- ▶ RIP and OSPF

Question No: 13 (Marks: 1) - Please choose one

_____measures distance in network hops, where each network between the source and destination counts as single hop.

- ▶ BGP
- ▶ OSPF
- ▶ **RIP (Page 138)**
- ▶ Non of these

Question No: 14 (Marks: 1) - Please choose one

_____ includes a 32-bits address mask with each address, which allows the address to be classful, classless, or subnetted.

- ▶ RIP
- ▶ **OSPF (Page 140)**
- ▶ BGP
- ▶ None of the given

Muhammad Moaaz Siddiq MCS (3rd)

mc100401285@Gmail.com

Campus:- Institute of E-Learning & Modern Studies
(IEMS) Samundari

Question No: 15 (Marks: 1) - Please choose one

One repeater -----, two repeaters ----- the maximum cable length limitation.

- ▶ **Double, triple** (Page 49)
- ▶ Double, 4 time
- ▶ half, triple
- ▶ Double, half

Question No: 16 (Marks: 1) - Please choose one

ICMP message transport is acted upon by getting ICMP encrypted in IP.

- ▶ **True** (Page 117)
- ▶ False

Question No: 17 (Marks: 1) - Please choose one

Like most application programs, a client and server use a transport protocol to communicate.

- ▶ **True** (Page 146)
- ▶ False

Question No: 18 (Marks: 1) - Please choose one

Mapping between a protocol address and a hardware address is called Address Resolution.

- ▶ **True** (Page 93)
- ▶ False

Question No: 19 (Marks: 1) - Please choose one

Address mask defines how many bits of address are in suffix?

- ▶ True
- ▶ **False** (Page 103)

Question No: 20 (Marks: 1) - Please choose one

A single networking technology is best for all needs.

- ▶ True
- ▶ **False** (Page 81)

Question No: 21 (Marks: 1) - Please choose one

In the 1970s large organizations began to acquire multiple networks. Each network in the organization formed island. Employees needed to choose a computer appropriate for each task. So they needed multiple screens, keyboards and computers.

- ▶ False
- ▶ **True** (Page 81) rep

Muhammad Moaaz Siddiq MCS (3rd)

mc100401285@Gmail.com

Campus:- Institute of E-Learning & Modern Studies
(IEMS) Samundari

Question No: 22 (Marks: 1) - Please choose one

Router detects datagram-----than network MTU

- ▶ **Larger (Page 108) rep**
- ▶ Smaller
- ▶ None of given
- ▶ Equal

Question No: 23 (Marks: 1) - Please choose one

Information can flow in either or both direction between

- ▶ Clients
- ▶ **Clients and servers (Computer Networks and Internets, page 344)**
- ▶ Servers
- ▶ None of given

Question No: 24 (Marks: 1) - Please choose one

On of the design goals for unicast route propagation is _____.

- ▶ consistency
- ▶ inconsistency
- ▶ **stability (Computer Networks and Internets, page 344)**
- ▶ dynamic addressing

Question No: 25 (Marks: 1) - Please choose one

IPV6 address consists of _____

- ▶ 32 Bits
- ▶ 64 Bits
- ▶ **128 Bits (Page 128)**
- ▶ none of the given

Question No: 26 (Marks: 1) - Please choose one

UDP offers application programs a Message-Oriented Interface, applications can depend on protocol to preserve data boundaries.

- ▶ **True (Page 120)**
- ▶ False

Question No: 27 (Marks: 1) - Please choose one

In case TCP, retransmission, acknowledgment from a computer on LAN are expected to arrive within

- ▶ Seconds
- ▶ Micro seconds
- ▶ **Milliseconds (Click here for detail)**
- ▶ Nanoseconds

Muhammad Moaaz Siddiq MCS (3rd)

mc100401285@gmail.com

Campus:- Institute of E-Learning & Modern Studies
(IEMS) Samundari

Question No: 28 (Marks: 1) - Please choose one

Twice NAT is another variant of NAT. it is used with site that runs server. In this process NAT box is connected to Domain Name.

- ▶ **True (Page 131)**
- ▶ False

Question No: 29 (Marks: 1) - Please choose one

A network uses a -----arranges for computers to be connected in a closed loop.

- ▶ Star Topology
- ▶ **Ring Topology (Page 25)**
- ▶ Bus Topology
- ▶ None of the given

Question No: 30 (Marks: 1) - Please choose one

Protocol addresses are abstractions provided by _____.

- ▶ hardware
- ▶ **software (Page 93)**
- ▶ operating system
- ▶ internet

FINAL TERM EXAMINATION

Fall 2008

CS610- Computer Network

Question No: 1 (Marks: 1) - Please choose one

In Direct point to point communication adding the Nth computer requires----- new connections.

- ▶ None of the given
- ▶ N2
- ▶ **N-1 (Page 23)**
- ▶ $(N^2 - N)/2$

Muhammad Moaaz Siddiq MCS (3rd)

mc100401285@gmail.com

Campus:- Institute of E-Learning & Modern Studies
(IEMS) Samundari

Question No: 2 (Marks: 1) - Please choose one

In Point-to-Point topology there are two topologies.

- ▶ Tree and Ring
- ▶ Star and Ring
- ▶ **Star and Tree (Page 5)**
- ▶ None of the given

Question No: 3 (Marks: 1) - Please choose one

In -----, network occupies the smaller area like a room a floor or a building

- ▶ **LAN (Page 4)**
- ▶ WAN
- ▶ MAN
- ▶ None of the given

Question No: 4 (Marks: 1) - Please choose one

Hardware that calculates a CRC uses two simple components.

- ▶ AND unit and XOR unit
- ▶ **Shift register and XOR unit (Page 20)**
- ▶ Shift register and AND unit
- ▶ None of the given

Question No: 5 (Marks: 1) - Please choose one

CRC can detect more errors than a simple checksum.

- ▶ **true (Computer Networks and Internets, page 80)**
- ▶ false

Question No: 6 (Marks: 1) - Please choose one

The Gigabit Ethernet hardware operates at a rate of -----

- ▶ 10 Mbps
- ▶ 100 Mbps
- ▶ **1000 Mbps Click here for detail**
- ▶ None of the given

Question No: 7 (Marks: 1) - Please choose one

Formally named _____ informally known as the twisted pair Ethernet or TP Ethernet.

- ▶ 10 Base 2
- ▶ 10 Base 5
- ▶ **10 Base T (Page 43)**
- ▶ None of the given

Muhammad Moaaz Siddiq MCS (3rd)

mc100401285@gmail.com

Campus:- Institute of E-Learning & Modern Studies
(IEMS) Samundari

Question No: 8 (Marks: 1) - Please choose one

An interface for thin Ethernet must have an _____ connector , and must generate signals according to the _____ specification.

- ▶ **RJ-45, 10 Base T**
- ▶ RJ-45, 10 Base 5
- ▶ **BNC, 10 Base 2 (cs610 reference book Page 201)**
- ▶ BNC, 10 Base T

Question No: 9 (Marks: 1) - Please choose one

A system with redundant bridges might have a problem with _____ in the system.

- ▶ **Loop** [Click here for detail](#) **rep**
- ▶ Filters
- ▶ Spanning Trees
- ▶ All given choices

Question No: 10 (Marks: 1) - Please choose one

_____ computes shortest paths in a graph by using weights on edges as a measure of distance.

- ▶ Greedy algorithm
- ▶ Distance vector algorithm
- ▶ **Dijkstra's algorithm (Computer Networks and Internets, page 112)**
- ▶ Non of the given

Question No: 11 (Marks: 1) - Please choose one

Basic LAN technologies such as Ethernet, Token Ring, and FDDI use a _____.

- ▶ **Connectionless service paradigm (Computer Networks and Internets, page 112)**
- ▶ Connection-oriented service paradigm
- ▶ Both Connectionless and Connection-oriented service paradigm
- ▶ None of the given

Question No: 12 (Marks: 1) - Please choose one

_____ protocols of TCP/IP layering model specify how to ensure reliable transfer.

- ▶ Physical Layer
- ▶ Network Interface Layer
- ▶ Internet Layer
- ▶ **Transport Layer (Page 84) rep**

Muhammad Moaaz Siddiq MCS (3rd)

mc100401285@gmail.com

Campus:- Institute of E-Learning & Modern Studies
(IEMS) Samundari

Question No: 13 (Marks: 1) - Please choose one

An Internet Address (IP address) is a unique _____ binary number assigned to a host and used for all communication with host

- ▶ 48-bit
- ▶ **32-bit (Page 85)**
- ▶ 24-bit
- ▶ None of the given

Question No: 14 (Marks: 1) - Please choose one

The address _____ identifies the physical network to which the computer is attached, while the _____ identifies an individual computer on that network.

▶ **prefix , suffix (Page 85)**

- ▶ suffix , prefix
- ▶ suffix , suffix
- ▶ None of the given

Question No: 15 (Marks: 1) - Please choose one

_____ places the boundary between the first and second octets

▶ **Class A (Computer Networks and Internets, page 235)**

- ▶ Class B
- ▶ Class C
- ▶ Class D

Question No: 16 (Marks: 1) - Please choose one

_____ places the boundary between the third and fourth octets.

- ▶ Class A
- ▶ Class B
- ▶ **Class C (Computer Networks and Internets, page 235)**
- ▶ Class D

Question No: 17 (Marks: 1) - Please choose one

_____ field of header indicates whether a datagram is a fragment or a complete datagram.

▶ **FLAGS** [Click here for detail](#)

- ▶ FLAGMENT OFFSET
- ▶ IDENTIFICATION
- ▶ None of the given

Muhammad Moaaz Siddiq MCS (3rd)

mc100401285@gmail.com

Campus:- Institute of E-Learning & Modern Studies
(IEMS) Samundari

Question No: 18 (Marks: 1) - Please choose one

_____ provides connectionless service.

- ▶ TCP
- ▶ **UDP (Page 120)**
- ▶ IP
- ▶ None of the given

Question No: 19 (Marks: 1) - Please choose one

UDP and TCP are both_____ layer protocols

- ▶ Physical
- ▶ Data link
- ▶ Network
- ▶ **Transport (Page 101) rep**

Question No: 20 (Marks: 1) - Please choose one

Connection-oriented service, Point-to-point, Complete reliability, Full-duplex communication, Stream interface, Reliable connection startup and Graceful connection shutdown are the services provided by_____

- ▶ IP
- ▶ None of the given
- ▶ **TCP (Page 123) rep**
- ▶ UDP

Question No: 21 (Marks: 1) - Please choose one

_____ protocols of TCP/IP layering model specify how to ensure reliable transfer.

- ▶ Physical Layer
- ▶ Network Interface Layer
- ▶ Internet Layer
- ▶ **Transport Layer (Page 84) rep**

Question No: 22 (Marks: 1) - Please choose one

_____ identifies which application program on receiving computer should receive the data

- ▶ Logical address
- ▶ Source port
- ▶ **Destination Port (Computer Networks and Internets, page313) rep**
- ▶ None of the given

Muhammad Moaaz Siddiq MCS (3rd)

mc100401285@gmail.com

Campus:- Institute of E-Learning & Modern Studies
(IEMS) Samundari

Question No: 23 (Marks: 1) - Please choose one

_____ identifies the application program that sent the data.

- ▶ DestinationPort
- ▶ **Source port (Computer Networks and Internets, page313) rep**
- ▶ Logical address
- ▶ None of the given

Question No: 24 (Marks: 1) - Please choose one

The Border Gateway Protocol (BGP) uses _____ for all communication

- ▶ UDP
- ▶ **TCP Click here for detail rep**
- ▶ Both UDP and TCP
- ▶ None of the given

Question No: 25 (Marks: 1) - Please choose one

Which of the following protocols allows the sender and receiver to enforce policies.

- ▶ RIP
- ▶ OSPF
- ▶ **BGP (Reference Book 347) rep**
- ▶ RIP and OSPF

Question No: 26 (Marks: 1) - Please choose one

_____ uses distance vector approach to define routing

- ▶ BGP
- ▶ OSPF
- ▶ **RIP (Computer Networks and Internets, page332)**
- ▶ None of the given

Question No: 27 (Marks: 1) - Please choose one

ICMP message transport is acted upon by getting ICMP encrypted in IP.

- ▶ **True (Page 117)**
- ▶ False

Muhammad Moaaz Siddiq MCS (3rd)

mc100401285@gmail.com

Campus:- Institute of E-Learning & Modern Studies
(IEMS) Samundari

Question No: 28 (Marks: 1) - Please choose one

Protocol addresses are abstractions provided by _____.

- ▶ hardware
- ▶ **software (Page 93) rep**
- ▶ operating system
- ▶ internet

Question No: 29 (Marks: 1) - Please choose one

These packets serve same purpose on _____ as frames on _____

- ▶ Intranet, LAN
- ▶ Internet, WAN
- ▶ Intranet, WAN
- ▶ **Internet, LAN (Page 101)**

Question No: 30 (Marks: 1) - Please choose one

Address mask defines how many bits of address are in suffix?

- ▶ True
- ▶ **False (Page 103) rep**

Question No: 31 (Marks: 1) - Please choose one

A single networking technology is best for all needs.

- ▶ True
- ▶ **False (Page 81) rep**

Question No: 32 (Marks: 1) - Please choose one

A computer attached to a given network can only communicate with other computers attached to the same network. Is this a problem with multiple networks?

- ▶ **True (Page 81) rep**
- ▶ False

Question No: 33 (Marks: 1) - Please choose one

The term self-identifying is used for Classful IP addresses because the class of the address can be computed from the address_____.

- ▶ **itself (Page 87)**
- ▶ prefix
- ▶ suffix
- ▶ mask

Muhammad Moaaz Siddiq MCS (3rd)

mc100401285@gmail.com

Campus:- Institute of E-Learning & Modern Studies
(IEMS) Samundari

Question No: 34 (Marks: 1) - Please choose one

Find the class of the address.

10100111 11011011 10001011 01101111

- ▶ A
- ▶ **B (Computer Networks and Internets, page 122)**
- ▶ E
- ▶ C

Question No: 35 (Marks: 1) - Please choose one

Find the class of the address:

11110011 10011011 11111011 00001111

- ▶ A
- ▶ C
- ▶ **E (Computer Networks and Internets, page 122)**
- ▶ B

Question No: 36 (Marks: 1) - Please choose one

In which method of Address Resolution Protocol the protocol address is determined by hardware address?
Were "T" stands for Table lookup, "C" for Closed-form Computation and "D" for Data Exchange?

- ▶ T
- ▶ D
- ▶ **C (Page 97) rep**
- ▶ T, C

Question No: 37 (Marks: 1) - Please choose one

Which method of Address Resolution Protocol requires hardware broadcast?

Were "T" stands for Table lookup, "C" for Closed-form Computation and "D" for Data Exchange?

- ▶ **D (Page 97)**
- ▶ T
- ▶ C
- ▶ T, D

Muhammad Moaaz Siddiq MCS (3rd)

mc100401285@gmail.com

Campus:- Institute of E-Learning & Modern Studies
(IEMS) Samundari

Question No: 38 (Marks: 1) - Please choose one

Which method of Address Resolution Protocol resolution with minimum delay?

Were "T" stands for Table lookup, "C" for Closed-form Computation and "D" for Data Exchange?

- ▶ T, D
- ▶ c
- ▶ T
- ▶ **T, C (Page 97)**

Question No: 39 (Marks: 1) - Please choose one

In which method of Address Resolution Protocol the implimentation is more difficult?

Were "T" stands for Table lookup, "C" for Closed-form Computation and "D" for Data Exchange?

- ▶ T, C
- ▶ T
- ▶ C
- ▶ **D (Page 97)**

Question No: 40 (Marks: 1) - Please choose one

On of the design goals for unicast route propagation is _____.

- ▶ Consistency
- ▶ inconsistency
- ▶ **stability (Computer Networks and Internets, page 344) rep**
- ▶ dynamic addressing

Question No: 41 (Marks: 1) - Please choose one

Propagation multicast routing information differs dramatically from unicast route propagation?

- ▶ **True (Computer Networks and Internets, page 335)**
- ▶ False

Question No: 42 (Marks: 1) - Please choose one

The IP multicast abstraction allows an application running on an arbitrary computer to leave a multicast group at any time. While _____ application on a computer remain a member of a group.

- ▶ One or more
- ▶ only one
- ▶ no
- ▶ many

Muhammad Moaaz Siddiq MCS (3rd)

mc100401285@gmail.com

Campus:- Institute of E-Learning & Modern Studies
(IEMS) Samundari

Question No: 43 (Marks: 1) - Please choose one

To save traffic, an EGP does not summarize routing information from the autonomous system before passing it to another autonomous system.

- ▶ True
- ▶ **False (Computer Networks and Internets, page 329)**

Question No: 44 (Marks: 1) - Please choose one

In IPv6 the type of address used for collection of computers with same prefix. Are known as_____.

- ▶ Anycast
- ▶ Unicast
- ▶ Multicast
- ▶ **Non of the given (Page 114)**

Question No: 45 (Marks: 1) - Please choose one

Special types of addresses in IPv6 used for multiple destinations; possibly not at same site. Are known as_____.

- ▶ Unicast
- ▶ Anycast
- ▶ **Multicast (Page 114)**
- ▶ Non of the given

Question No: 46 (Marks: 1) - Please choose one

UDP offers application programs a Message-Oriented Interface, applications can depend on protocol to preserve data boundaries.

- ▶ **True (Page 120) rep**
- ▶ False

Question No: 47 (Marks: 1) - Please choose one

Reliability is the responsibility of the _____ layer

- ▶ Network
- ▶ Datalink
- ▶ **Transport (Page 123)**
- ▶ Application

Muhammad Moaaz Siddiq MCS (3rd)

mc100401285@gmail.com

Campus:- Institute of E-Learning & Modern Studies
(IEMS) Samundari

Question No: 48 (Marks: 1) - Please choose one

TCP uses _____ mechanism to control the flow of data.

- ▶ door
- ▶ **window (Page 126) rep**
- ▶ acknowledgment
- ▶ retransmission

TCP uses window mechanism to control the flow of data.

Question No: 49 (Marks: 1) - Please choose one

The time for acknowledgement to arrival of packet depends on.

- ▶ **Distance to destination and Current traffic conditions (Page 125)**
- ▶ Current traffic conditions
- ▶ Distance to destination
- ▶ non of these

Question No: 50 (Marks: 1) - Please choose one

FDDI can transmits data at a rate of -----

- ▶ **100 million bits per second (Page 31)**
- ▶ 10 million bits per second
- ▶ 1000 million bits per second
- ▶ None of the given

FINAL TERM EXAMINATION Fall 2008
CS610- Computer Network

Question No: 1 (Marks: 1)

Computer networks are often called ----- because they use packet technology.

- ▶ Ethernet
- ▶ Switch networks
- ▶ **Packet networks (Computer Networks and Internets, page 73)**
- ▶ None of the given

Question No: 2 (Marks: 1)

A network uses a -----arranges for computers to be connected in a closed loop.

- ▶ Star Topology
- ▶ **Ring Topology (Page 25) rep**
- ▶ Bus Topology

- ▶ None of the given

Question No: 3 (Marks: 1)

An -----method, the network hardware designers specify how type information is included in the frame and the value use to identify various frame types.

- ▶ **Explicit frame type (Computer Networks and Internets, page 108)**
- ▶ Ideal frame type
- ▶ Implicit frame type
- ▶ None of the given

Question No: 4 (Marks: 1)

An interface for thin Ethernet must have an _____ connector , and must generate signals according to the_____ specification.

- ▶ RJ-45, 10 Base T
- ▶ RJ-45, 10 Base 5
- ▶ **BNC, 10 Base 2 (cs610 reference book Page 201) rep**
- ▶ BNC, 10 Base T

Question No: 5 (Marks: 1)

A Bridge forwards or filters a frame by comparing the information in its address table to the frame's_____

- ▶ Layer 2 source address
- ▶ Source node's physical address
- ▶ **Layer 2 destination address** [Click here for detail](#)
- ▶ Layer 3 destination address

Question No: 6 (Marks: 1)

Most WAN systems include a mechanism that can be used to eliminate the common case of duplication routing is called_____

- ▶ Hierarchal address
- ▶ **Default route (Computer Networks and Internets, page 172)**
- ▶ Shortest path
- ▶ None of the given

Question No: 7 (Marks: 1)

_____ of TCP/IP layering model, corresponds to basic network hardware.

- ▶ **Physical Layer (Page 84) rep**
- ▶ Network Interface Layer
- ▶ Internet Layer
- ▶ Transport Layer

Muhammad Moaaz Siddiq MCS (3rd)

mc100401285@gmail.com

Campus:- Institute of E-Learning & Modern Studies
(IEMS) Samundari

Question No: 8 (Marks: 1)

_____ protocols of TCP/IP layering model specify how to ensure reliable transfer.

- ▶ Physical Layer
- ▶ Network Interface Layer
- ▶ Internet Layer
- ▶ **Transport Layer (Page 84) rep**

Question No: 9 (Marks: 1)

_____ is called an end-to-end protocol because it provide a connection directly from an application on one computer to an application on a remote computer.

- ▶ IP
- ▶ UDP
- ▶ **TCP (Computer Networks and Internets, page 306)**
- ▶ None of the given

Question No: 10 (Marks: 1)

_____ uses distance vector approach to define routing

- ▶ BGP
- ▶ OSPF
- ▶ **RIP (Computer Networks and Internets, page332) rep**
- ▶ None of the given

Question No: 11 (Marks: 1)

_____ is ideal in a situation where the group is small and all members are attached to contiguous Local Area Networks.

- ▶ **Flood-and -Prune (Page 143)**
- ▶ Configuration-and -Tunneling
- ▶ Core-Based Discovery
- ▶ None of the given

Question No: 12 (Marks: 1)

Router that decrements TTL to __ sends ICMP time exceeded message, with router's address as source address

- ▶ 3
- ▶ 2
- ▶ 1
- ▶ **0 (Page 118)**

Muhammad Moaaz Siddiq MCS (3rd)

mc100401285@gmail.com

Campus:- Institute of E-Learning & Modern Studies
(IEMS) Samundari

Question No: 13 (Marks: 1)

Protocol addresses are abstractions provided by _____.

- ▶ hardware
- ▶ **software (Page 93) rep**
- ▶ operating system
- ▶ internet

Question No: 14 (Marks: 1)

Although message exchange can be used to bind addresses, sending a request for each binding is hopelessly inefficient.

- ▶ **True (Page 99) rep**
- ▶ False

Question No: 15 (Marks: 1)

ARP is almost always used to bind a ___-bit IP address to a ___-bit Ethernet address.

- ▶ **32, 48 (Page 98)**
- ▶ 24, 32
- ▶ 32, 64
- ▶ 32, 128

Question No: 16 (Marks: 1)

In the 1970s large organizations began to acquire multiple networks. Each network in the organization formed island. Employees needed to choose a computer appropriate for each task. So they needed multiple screens, keyboards and computers.

- ▶ False
- ▶ **True (Page 81) rep**

Question No: 17 (Marks: 1)

In which method of Address Resolution Protocol the protocol address is determined by hardware address? Were "T" stands for Table lookup, "C" for Closed-form Computation and "D" for Data Exchange?

Features	Types of Resolution
Use full with any hardware	T
Address change affects all hosts	T
Protocol address is determined by hardware address	C

- ▶ T
- ▶ D
- ▶ **C (Page 97) rep**
- ▶ T, C

Muhammad Moaaz Siddiq MCS (3rd)

mc100401285@gmail.com

Campus:- Institute of E-Learning & Modern Studies
(IEMS) Samundari

Question No: 18 (Marks: 1)

The general form of an IP datagram is with a header followed by data. The header contains information that controls where and how the datagram is to be sent.

- ▶ **True (Computer Networks and Internets, page 332)**
- ▶ False

Question No: 19 (Marks: 1)

To save traffic, an EGP does not summarize routing information from the autonomous system before passing it to another autonomous system.

- ▶ True
- ▶ **False (Computer Networks and Internets, page 329)**

Question No: 20 (Marks: 1)

Which of the following is a correct representation of the IPv6?

- ▶ **105.220.136.100.255.255.255.0.0.18.128.140.10.255.255 (Page 114)**
- ▶ 105.220.136.100.255.255.255.256.0.0.18.128.140.10.255.255
- ▶ 105.220.136.100.255.255.255.255.0.0.18.128.140.10.255.255.256
- ▶ 105.220.136.100.255.255.255.255.0.0.18.128.140.10.255

**FINAL TERM EXAMINATION
Fall 2008
CS610- Computer Network**

Question No: 1 (Marks: 1) - Please choose one

The number of connections needed for N computer in direct point to point communication is equal to:

- ▶ **$(N^2 - N)/2$ (Page 23)**
- ▶ $N(N - 1)$
- ▶ N^2
- ▶ None of the given

Question No: 2 (Marks: 1) - Please choose one

When an application----- data, it makes a copy of the data available to all other computers on the network.

- ▶ **Broadcasting** [Click here for detail](#)
- ▶ Multicasting
- ▶ Unicasting
- ▶ None of the given

Question No: 3 (Marks: 1) - Please choose one

Ethernet uses a ----- bit static addressing scheme in which each device is assigned a unique address by the manufacturer.

- ▶ 64
- ▶ **48 (Computer Networks and Internets, page 109)**
- ▶ 32
- ▶ 8

Question No: 4 (Marks: 1) - Please choose one

A system with redundant bridges might have a problem with _____ in the system.

- ▶ **Loop (Click here for detail) rep**
- ▶ Filters
- ▶ Spanning Trees
- ▶ All given choices

Question No: 5 (Marks: 1) - Please choose one

The product of delay and throughput measures the _____ of data that can be present on the network.

- ▶ Area
- ▶ **Volume (Page 80) rep**
- ▶ Length
- ▶ None of the given

Question No: 6 (Marks: 1) - Please choose one

Connectionless service, Message-Oriented protocol, best effort delivery service, arbitrary interaction and operating system independent are the characteristics of _____

- ▶ TCP
- ▶ **UDP (Page 110)**
- ▶ IP
- ▶ None of the given

Question No: 7 (Marks: 1) - Please choose one

Connection-oriented service, Point-to-point, Complete reliability, Full-duplex communication, Stream interface, Reliable connection startup and Graceful connection shutdown are the services provided by _____

- ▶ None of the given
- ▶ **TCP (Page 123) rep**
- ▶ UDP
- ▶ IP

Muhammad Moaaz Siddiq MCS (3rd)

mc100401285@gmail.com

Campus:- Institute of E-Learning & Modern Studies
(IEMS) Samundari

Question No: 8 (Marks: 1) - Please choose one

The process of using a routing table to select a next hop for a given datagram is called_____

- ▶ Encapsulation
- ▶ Reassembling
- ▶ **Routing or forwarding (Computer Networks and Internets, page 265)**
- ▶ None of the given

Question No: 9 (Marks: 1) - Please choose one

_____ uses distance vector approach to define routing

- ▶ BGP
- ▶ OSPF
- ▶ **RIP (Computer Networks and Internets, page332) rep**
- ▶ None of the given

Question No: 10 (Marks: 1) - Please choose one

A multicast routing scheme in which the protocol software builds a delivery tree from a central point is called_____

- ▶ Distance Vector Multicast Routing Protocol (DVMRP)
- ▶ **Core Based Trees (CBT) (Page 114)**
- ▶ Protocol Independent Multicast_ *Sparse Mode (PIM-SM)*
- ▶ Protocol Independent Multicast_ *Dense Mode (PIM-DM)*

Question No: 11 (Marks: 1) - Please choose one

One repeater _____, two repeaters _____ the maximum cable length limitation.

- ▶ doubles, cancel
- ▶ **doubles, triple (Page 49) rep**
- ▶ square roots, cude roots
- ▶ and, triple

Question No: 12 (Marks: 1) - Please choose one

Whenever it handles a packet, IP software needs to separate the destination address into a _____ and _____.

- ▶ postfix, Infix
- ▶ non of these
- ▶ Infix, prefix
- ▶ **prefix, suffix (Page 87)**

Muhammad Moaaz Siddiq MCS (3rd)

mc100401285@gmail.com

Campus:- Institute of E-Learning & Modern Studies
(IEMS) Samundari

Question No: 13 (Marks: 1) - Please choose one

Although message exchange can be used to bind addresses, sending a request for each binding is hopelessly inefficient.

- ▶ True (Page 99) rep
- ▶ False

Question No: 14 (Marks: 1) - Please choose one

ARP is almost always used to bind a ___-bit IP address to a ___-bit Ethernet address.

- ▶ 32, 48 (Page 98)
- ▶ 24, 32
- ▶ 32, 64
- ▶ 32, 128

Question No: 15 (Marks: 1) - Please choose one

End-to-end delivery service is connection oriented.

- ▶ True
- ▶ False (Page 101)

Question No: 16 (Marks: 1) - Please choose one

A single networking technology is best for all needs.

- ▶ True
- ▶ False (Page 81) rep

Question No: 17 (Marks: 1) - Please choose one

In the 1970s large organizations began to acquire multiple networks. Each network in the organization formed island. Employees needed to choose a computer appropriate for each task. So they needed multiple screens, keyboards and computers.

- ▶ False
- ▶ True (Page 81)

Question No: 18 (Marks: 1) - Please choose one

Which method of Address Resolution Protocol is useful with any hardware?

Were "T" stands for Table lookup, "C" for Closed-form Computation and "D" for Data Exchange?

- ▶ T (Page 97)
- ▶ C
- ▶ D
- ▶ C, D

Question No: 19 (Marks: 1) - Please choose one

In which method of Address Resolution Protocol the protocol address is determined by hardware address?
Were "T" stands for Table lookup, "C" for Closed-form Computation and "D" for Data Exchange?

- ▶ T
- ▶ D
- ▶ **C**
- ▶ T, C

(Page 97) rep

Question No: 20 (Marks: 1) - Please choose one

We use the term _____ to refer to a measure of the path that routing software use when choosing a route.

- ▶ routing path
- ▶ routing metric
- ▶ **routing**
- ▶ switching

(Computer Networks and Internets, page330)

Muhammad Moaaz Siddiq MCS (3rd)

mc100401285@gmail.com

Campus:- Institute of E-Learning & Modern Studies
(IEMS) Samundari